

## OPERATION AND INSTALLATION

Electronically controlled comfort instantaneous water heater

- » DHB-E 13 LCD AU
- » DHB-E 18 LCD AU
- » DHB-E 27 LCD AU

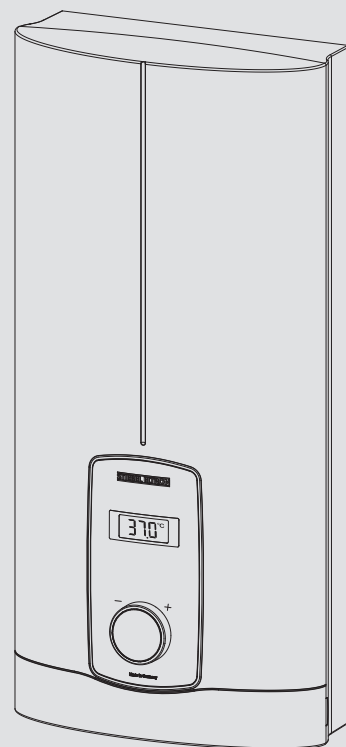

**STIEBEL ELTRON**

---

# CONTENTS

---

## OPERATION

<b>1. General information</b>	<b>3</b>
1.1 Safety instructions	3
1.2 Other symbols in this documentation	4
1.3 Units of measurement	4
<b>2. Safety</b>	<b>4</b>
2.1 Intended use	4
2.2 General safety instructions	4
<b>3. Appliance description</b>	<b>4</b>
<b>4. Settings and displays</b>	<b>5</b>
4.1 Setting the temperature	5
4.2 Recommended settings	5
<b>5. Cleaning, care and maintenance</b>	<b>5</b>
<b>6. Troubleshooting</b>	<b>6</b>

## INSTALLATION

<b>7. Safety</b>	<b>7</b>
7.1 General safety instructions	7
7.2 Shower operation	7
7.3 Instructions, standards and regulations	7
<b>8. Appliance description</b>	<b>7</b>
8.1 Standard delivery	7
8.2 Accessories	7
<b>9. Preparation</b>	<b>8</b>
9.1 Installation location	8
9.2 Minimum clearances	8
9.3 Water installation	8
<b>10. Installation</b>	<b>9</b>
10.1 Standard installation	9
<b>11. Commissioning</b>	<b>11</b>
11.1 Preparation	11
11.2 Initial start-up	11
11.3 Recommissioning	12
<b>12. Appliance shutdown</b>	<b>12</b>
<b>13. Alternative installation methods</b>	<b>12</b>
13.1 Electrical connection from above on unfinished walls	12
13.2 Electrical connection on unfinished walls with short power cable	13
13.3 Electrical connection on finished walls	13
13.4 Connecting a load shedding relay	13
13.5 Water installation on unfinished walls	13
13.6 Wall mounting bracket when replacing appliance	14
13.7 Installation with offset tiles	14
13.8 Pivoting appliance cover	14
13.9 Operation with preheated water	14
<b>14. Service information</b>	<b>15</b>
<b>15. Troubleshooting</b>	<b>15</b>
<b>16. Maintenance</b>	<b>16</b>
<b>17. Specification</b>	<b>16</b>
17.1 Dimensions and connections	16
17.2 Wiring diagram	17
17.3 Domestic hot water output	17
17.4 Application areas / Conversion table	17

17.5 Pressure drop	17
17.6 Fault conditions	17
17.7 Test symbols	17
17.8 Data table	18

## ENVIRONMENT AND RECYCLING

## GUARANTEE

# SPECIAL INFORMATION OPERATION

- The appliance may be used by children aged 3 and older and persons with reduced physical, sensory or mental capabilities or a lack of experience and know-how, provided that they are supervised or they have been instructed on how to use the appliance safely and have understood the potential risks. Children must never play with the appliance. Cleaning and maintenance by the user may not be carried out by children unless they are supervised.
- The tap can reach temperatures of up to 70 °C. There is a risk of scalding at outlet temperatures in excess of 43 °C.
- The appliance is suitable for supplying a shower (shower operation). If the appliance is also or exclusively used for shower operation, the qualified contractor must adjust the temperature setting range to 43 °C using the internal anti-scalding protection on the appliance. When using preheated water, it must be ensured that the inlet temperature does not exceed 55 °C.
- Ensure the appliance can be separated from the power supply by an isolator that disconnects all poles with at least 3 mm contact separation.
- The specified voltage must match the power supply.
- The appliance must be connected to the earth conductor.
- The appliance must be permanently connected to fixed wiring.
- Secure the appliance as described in chapter "Installation / Installation".
- Observe the maximum permissible pressure (see chapter "Installation / Specification / Data table").
- The specific water resistivity of the mains water supply must not be undershot (see chapter "Installation / Specification / Data table").
- Drain the appliance as described in chapter "Installation / Maintenance / Draining the appliance".

## 1. General information

The chapters "Special information" and "Operation" are intended for both users and qualified contractors.

The chapter "Installation" is intended for qualified contractors.



**Note**  
 Read these instructions carefully before using the appliance and retain them for future reference.  
 Pass on the instructions to a new user if required.

### 1.1 Safety instructions

#### 1.1.1 Structure of safety instructions



**KEYWORD Type of risk**  
 Here, possible consequences are listed that may result from failure to observe the safety instructions.  
 ► Steps to prevent the risk are listed.

#### 1.1.2 Symbols, type of risk

Symbol	Type of risk
	Injury
	Electrocution
	Burns (burns, scalding)

#### 1.1.3 Keywords

KEYWORD	Meaning
DANGER	Failure to observe this information will result in serious injury or death.
WARNING	Failure to observe this information may result in serious injury or death.
CAUTION	Failure to observe this information may result in non-serious or minor injury.

### 1.2 Other symbols in this documentation



#### Note

General information is identified by the adjacent symbol.  
▶ Read these texts carefully.

Symbol	Meaning
	Material losses (appliance damage, consequential losses and environmental pollution)
	Appliance disposal

▶ This symbol indicates that you have to do something. The action you need to take is described step by step.

### 1.3 Units of measurement



#### Note

All measurements are given in mm unless stated otherwise.

## 2. Safety

### 2.1 Intended use

This appliance is suitable for heating domestic hot water or for reheating preheated water. The appliance can supply one or more draw-off points.

Water will not be reheated if the maximum inlet temperature for reheating is exceeded.

The appliance is intended for domestic use. It can be used safely by untrained persons. The appliance can also be used in non-domestic environments, e.g. in small businesses, as long as it is used in the same way.

Any other use beyond that described shall be deemed inappropriate. Observation of these instructions and of the instructions for any accessories used is also part of the correct use of this appliance.

### 2.2 General safety instructions



#### CAUTION Burns

During operation, the tap can reach temperatures up to 70 °C.

There is a risk of scalding at outlet temperatures in excess of 43 °C.



#### CAUTION Burns

If operating with preheated water, e.g. from a solar thermal system, the DHW temperature may vary from the selected set temperature.



#### WARNING Injury

The appliance may be used by children aged 3 and older and persons with reduced physical, sensory or mental capabilities or a lack of experience and know-how, provided that they are supervised or they have been instructed on how to use the appliance safely and have understood the potential risks. Children must never play with the appliance. Children must never clean the appliance or perform user maintenance unless they are supervised.

Where children or persons with limited physical, sensory or mental abilities are allowed to use this appliance, we recommend a permanent temperature limit.

- Qualified contractor adjustable: Internal anti-scalding protection.



#### Material losses

The user should protect the appliance and its tap against frost.

## 3. Appliance description

The appliance switches on automatically as soon as you open the hot water valve on the tap. When you close the tap, the appliance switches off again automatically.

The appliance heats water as it flows through it. The DHW outlet temperature can be variably adjusted. From a certain flow rate, the control unit regulates the correct heating output, subject to the temperature selected and the current cold water temperature.

The electronically controlled instantaneous water heater with automatic output matching maintains a consistent outlet temperature. It is irrespective of the inlet temperature, up to the maximum output of the appliance.

If the appliance is operated with preheated water and the inlet temperature exceeds the chosen set temperature, the water will not be heated further.

You can set the temperature unit (°C or °F) according to preference.

### Heating system

The bare wire heating system is enclosed within a pressure-tested plastic jacket. The heating system with its stainless steel internal indirect coil is suitable for hard and soft water areas and is largely unsusceptible to scale build-up. The heating system ensures rapid and efficient DHW provision.



#### Note

The appliance is equipped with an air detector that largely prevents damage to the heating system. If, during operation, air is drawn into the appliance, the appliance shuts down for one minute, thereby protecting the heating system.

## 4. Settings and displays

### 4.1 Setting the temperature

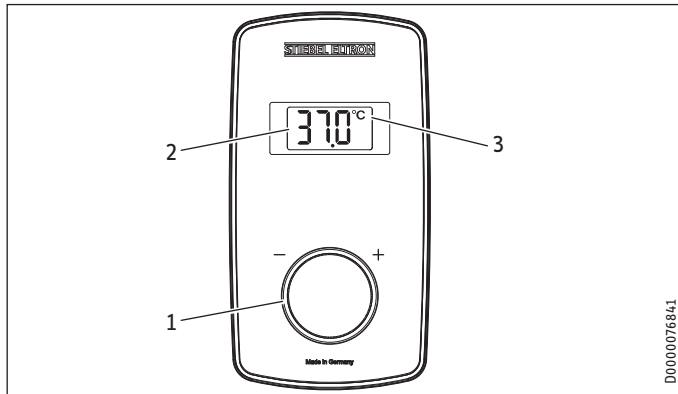

- 1 Temperature selector for adjusting set temperature (no end-stop): "OFF", 20 - 60 °C (factory setting)
- 2 Display
- 3 Temperature unit [°C/°F]

Temperature settings in steps			
Temperature range	Step	Temperature range	Step
20 °C ... 60 °C	1 °C	68 °F ... 140 °F	1 °F

#### Selecting the temperature indicator

You can choose to display the temperature in °C or °F, as required.

- ▶ Turn the temperature selector anti-clockwise, past the OFF indicator and another five complete turns, until you find yourself in temperature unit selection mode. Then select the temperature unit using the temperature selector. After 30 seconds, the appliance exits selection mode automatically and the selected temperature unit is retained.

**!** **Note**  
 If the outlet temperature is not high enough when the draw-off valve is fully open and the temperature selector is set to maximum, then more water is flowing through the appliance than can be heated by the heating system (appliance working at maximum output).  
 ▶ Reduce the water volume until the preferred temperature delivery is achieved.

### 4.2 Recommended settings

Your instantaneous water heater offers maximum precision and maximum convenience in DHW provision. Should you nonetheless be operating the appliance with a thermostatic valve, we recommend that you:

- ▶ Adjust the set temperature on the appliance to over 50 °C. Then set the required set temperature on the thermostatic valve.

#### Saving energy

The following recommended settings will result in the lowest energy consumption:

- 38 °C for hand washbasins, showers, bath
- 55 °C for kitchen sinks

#### Internal anti-scalding protection (qualified contractors)

If required, the qualified contractor can set a permanent temperature limit, for example in nurseries, hospitals etc.

When supplying a shower, the temperature setting range must be limited by the qualified contractor to 43 °C.

Limiting it in this way prevents water from flowing out of the appliance at temperatures which could cause injury.

#### Recommended setting for operation with a thermostatic valve and water preheated by solar energy

- ▶ Set the temperature at the appliance to the maximum temperature.

#### Following an interruption to the water supply

- !** **Material losses**  
 To ensure that the bare wire heating system is not damaged following an interruption to the water supply, the appliance must be restarted taking the following steps.
- ▶ Disconnect the appliance from the power supply by removing the fuses/tripping the MCBs.
  - ▶ Open the tap for one minute until the appliance and its upstream cold water inlet line are free of air.
  - ▶ Switch the power back ON.

## 5. Cleaning, care and maintenance

- ▶ Never use abrasive or corrosive cleaning agents. A damp cloth is sufficient for cleaning the appliance.
- ▶ Check the taps regularly. Limescale deposits at the tap outlets can be removed using commercially available descaling agents.

## 6. Troubleshooting

Problem	Cause	Remedy
The appliance will not start despite the DHW valve being fully open.	There is no power.	Check the fuses/MCBs in your fuse box/distribution board.
	The aerator in the tap or the shower head is scaled up or soiled.	Clean and/or descale the aerator or shower head.
	The water supply has been interrupted.	Vent the appliance and the cold water inlet line.
When hot water is being drawn off, cold water flows for a short period.	The air detector detects air in the water. It switches off the heating output briefly.	The appliance restarts automatically after 1 minute.
The required temperature cannot be set.	Internal anti-scalding protection is activated.	The internal anti-scalding protection can only be adjusted by the qualified contractor.



**Note**

After a power failure:  
Programming unit displays and selected settings are retained following a power failure.

If you cannot remedy the fault, contact your qualified contractor. To facilitate and speed up your request, provide the number from the type plate (000000-0000-000000).

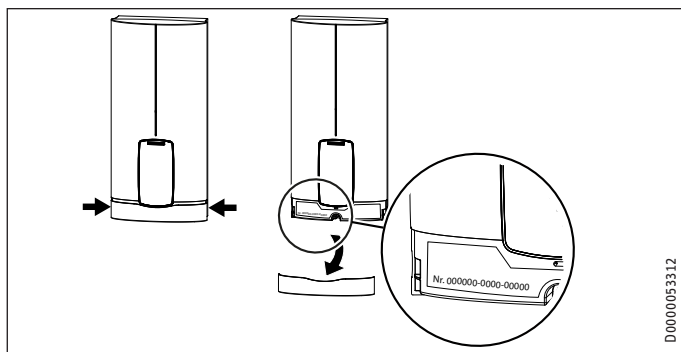

# INSTALLATION

## 7. Safety

Only a qualified contractor should carry out installation, commissioning, maintenance and repair of the appliance.

### 7.1 General safety instructions

We guarantee trouble-free function and operational reliability only if original accessories and spare parts intended for the appliance are used.



#### Material losses

Observe the maximum inlet temperature. Higher temperatures may damage the appliance. You can limit the maximum inlet temperature by installing a central thermostatic valve (see chapter "Appliance description / Accessories").



#### WARNING Electrocutation

This appliance contains capacitors which are discharged when disconnected from the power supply. The capacitor discharge voltage may briefly reach > 60 V DC.

### 7.2 Shower operation



#### CAUTION Burns

► When supplying a shower, set the internal anti-scalding protection to 43 °C; see chapter "Commissioning / Preparations".



#### CAUTION Burns

If the water supplied to the appliance is preheated, please note the following points:

- The internally adjustable anti-scalding protection may be exceeded.
- The dynamic anti-scalding protection between the appliance and the wireless remote control may not be effective.
- In both cases, limit the temperature with an upstream central thermostatic valve (ZTA 3/4).

### 7.3 Instructions, standards and regulations



#### Note

Observe all applicable national and regional regulations and instructions.

- The IP 25 (hoseproof) rating can only be ensured with a correctly fitted cable grommet.
- The specific electrical resistance of the water must not fall below that stated on the type plate. In a linked water network, factor in the lowest electrical resistance of the water. Your water supply utility will advise you of the specific electrical water resistance or conductivity.

## 8. Appliance description

### 8.1 Standard delivery

The following are delivered with the appliance:

- Wall mounting bracket
- Installation template
- 2 plugs
- 2 extensions
- 2 caps
- 2 tees
- 8 flat gaskets
- Strainer
- Flow limiter
- Plastic profile washer
- Plastic connection pieces / Installation aid
- Cap and back panel guides
- Jumper for internal anti-scalding protection

### 8.2 Accessories

#### Wireless remote control

- FFB 4 Set AP

#### Taps/valves

- MEKD mono lever kitchen pressure tap
- MEBD mono lever bath pressure tap

#### Plugs G ½ A

If you use other than the recommended pressure taps on finished walls, please use the plugs.

#### Installation set for finished walls

- Solder fitting - copper pipe for soldered connection Ø 12 mm
- Press-fit fitting - copper pipe
- Press-fit fitting - plastic pipe (suitable for Viega: Sanfix-Plus or Sanfix-Fosta)

#### Universal mounting frame

- Mounting frame with electrical connections

#### Pipe assembly for undersink appliances

You will need the undersink installation set if you make the water connections (G ¾ A) at the top of the appliance.

#### Pipe assembly for offset installation

Use this pipe assembly if you intend to offset the appliance by up to 90 mm downwards from the water connection.

#### Pipe assembly for replacing a gas water heater

You will need this pipe assembly set if the existing installation has gas water heater connections (cold water connection on the left-hand side, DHW connection on the right-hand side).

# INSTALLATION

## Preparation

### Pipe assembly for DHB water plug-in couplings

Use the water plug-in couplings if the existing installation contains water plug-in connections from a DHB water heater.

### Load shedding relay (LR 1-A)

The load shedding relay for installation in the distribution board provides priority control for the instantaneous water heater when other appliances, such as electric storage heaters, are being operated simultaneously.

### Central thermostatic valve (ZTA 3/4)

Use the thermostatic valve for central premixing when, for example, operating an instantaneous water heater with preheated water. For use in shower operation, the valve must be set to a maximum of 55 °C and internal anti-scalding protection must be set to 43 °C.

## 9. Preparation

### 9.1 Installation location

**!** **Material losses**  
Install the appliance in a room free from the risk of frost.

- ▶ Always install the appliance vertically and near the draw-off point.

The appliance is suitable for undersink and oversink installation.

#### Undersink installation

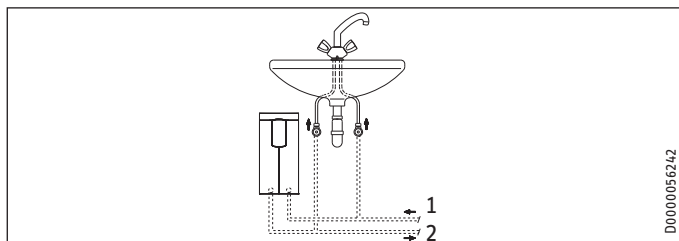

- 1 Cold water inlet
- 2 DHW outlet

#### Oversink installation

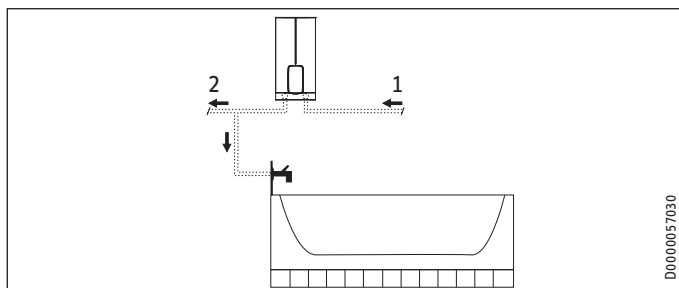

- 1 Cold water inlet
- 2 DHW outlet

**Note**  
▶ Mount the appliance on the wall. The wall must have sufficient load bearing capacity.

### 9.2 Minimum clearances

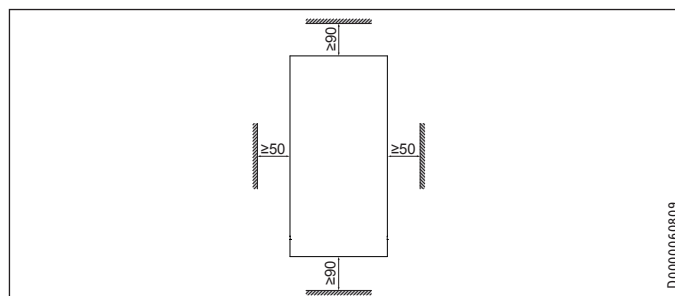

- ▶ Maintain the minimum clearances to ensure trouble-free operation of the appliance and facilitate maintenance work.

### 9.3 Water installation

- ▶ Flush the water line thoroughly.

#### Taps/valves

Use appropriate pressure taps. Open vented taps are not permissible.

#### Permissible water line materials

- Cold water inlet line:  
Pipes made from galvanised steel, stainless steel, copper or plastic
- DHW outlet line:  
Stainless steel pipe, copper pipe or plastic pipe

**!** **Material losses**  
If plastic pipework systems are used, take into account the maximum inlet temperature and the maximum permissible pressure.

#### Flow rate

- ▶ Ensure that the flow rate for switching on the appliance is achieved.
- ▶ Increase the water line pressure if the required flow rate is not achieved when the draw-off valve is fully open. If the flow rate is not reached despite increasing the pressure, remove the flow limiter and install the plastic profile washer (see chapter "Standard installation / Preparing the water connection").

**Note**  
For a thermostatic valve to function correctly, the flow limiter must not be replaced with the plastic profile washer.

### 10. Installation

Factory settings	DHB-E 13 LCD AU	DHB-E 18 LCD AU	DHB-E 27 LCD AU
Internal anti-scalding protection in °C	Tmax	Tmax	Tmax
Standard installation	DHB-E 13 LCD AU	DHB-E 18 LCD AU	DHB-E 27 LCD AU
Electrical connection from below on unfinished walls	x	x	x
Water connection, installation on finished walls	x	x	x

For further installation options, see chapter "Alternative installation methods".

#### 10.1 Standard installation

##### Opening the appliance

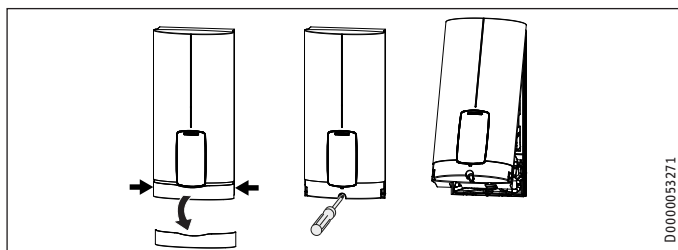

- ▶ Open the appliance by holding the fascia at the side and pulling forwards away from the appliance cover. Undo the screw. Pivot open the appliance cover.

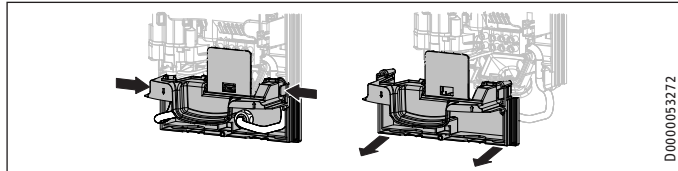

- ▶ Remove the back panel by pressing the two locking tabs and pulling the lower section of the back panel forwards.

##### Preparing the power cable on unfinished walls, for connection from below

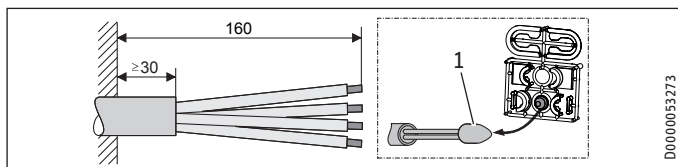

- 1 Cable entry installation aid
- ▶ Prepare the power cable.

##### Fitting the wall mounting bracket

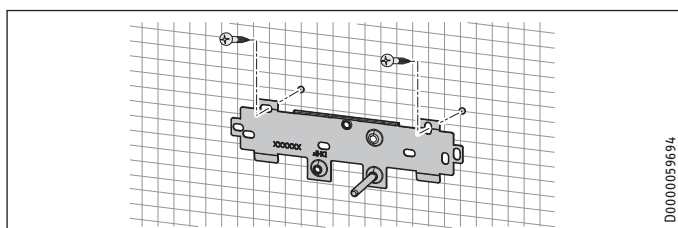

- ▶ Mark out the holes for drilling using the installation template. If the appliance is to be installed on finished walls, also mark out the fixing hole in the lower section of the template.

- ▶ Drill the holes and secure the wall mounting bracket at 2 points using suitable fixing materials (screws and rawl plugs are not part of the standard delivery).
- ▶ Fit the wall mounting bracket.

##### Preparing the water connection



##### Material losses

Carry out all water connection and installation work in accordance with regulations.

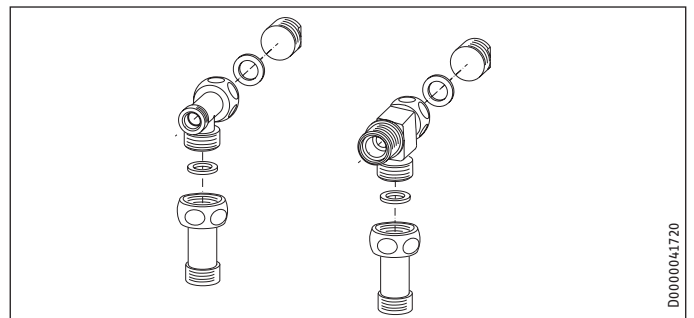

- ▶ Remove the caps from the tees.
- ▶ Fit the plugs and the extensions with gaskets.

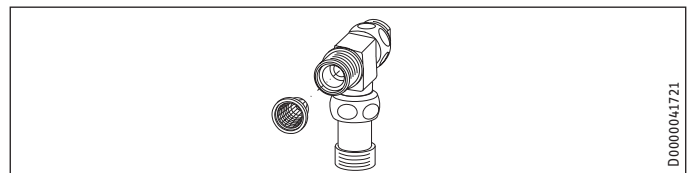

- ▶ Fit the strainer in the tee for the cold water inlet.



##### Damage to the appliance and environmental pollution

The strainer must be fitted for the appliance to function.

- ▶ When replacing the appliance, check that the strainer is present.

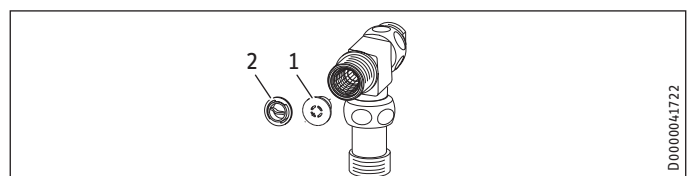

- 1 Flow limiter
  - 2 Plastic profile washer
- ▶ Fit the flow limiter or the plastic profile washer.

# INSTALLATION

## Installation



### Note

- ▶ Install the flow limiter. With low water pressure, the pressure drop can be reduced by replacing the flow limiter with the plastic profile washer provided.

### Installing the appliance



### Note

- If you are installing the appliance with flexible pipe connections, also secure the bottom of the back panel with a screw.

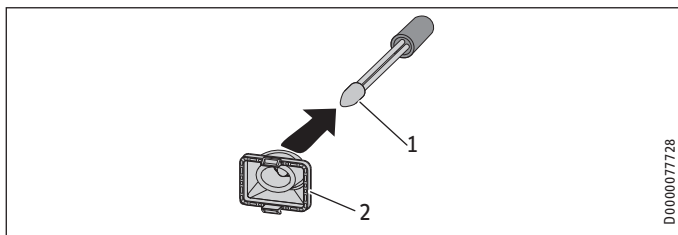

- 1 Cable entry installation aid
- 2 Cable grommet

Use the installation aid for easier wiring access through the cable grommet (see plastic parts set supplied).

- ▶ Remove the cable grommet from the back panel.
- ▶ Pull the cable grommet over the cable sheath of the power cable. For large cable cross-sections, enlarge the hole in the cable grommet if necessary.

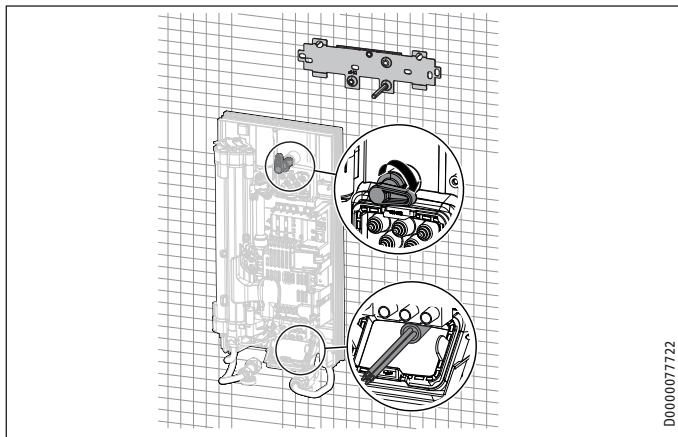

- ▶ Remove the transport protection plugs from the appliance pipe connections.
- ▶ Bend the power cable 45° upwards.
- ▶ Route the power cable and cable grommet through the back panel from the rear.
- ▶ Install the appliance on the threaded studs of the wall mounting bracket.
- ▶ Press the back panel firmly into place, aligning it correctly.
- ▶ Lock the fixing toggle by turning it 90° clockwise.
- ▶ Pull the cable grommets into the back panel, until both locking tabs engage.

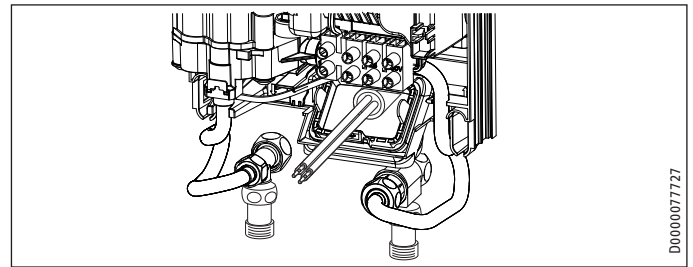

- ▶ Screw the pre-assembled parts with flat gaskets to the cold water and DHW pipes of the appliance.
- ▶ Fit the cold water inlet pipe and the DHW outlet pipe from the pipework with flat gaskets to the extensions from the appliance.

### Making the electrical connection



#### WARNING Electrocutation

Carry out all electrical connection and installation work in accordance with relevant regulations.



#### WARNING Electrocutation

The connection to the power supply must be in the form of a permanent connection in conjunction with the removable cable grommet. Ensure the appliance can be separated from the power supply by an isolator that disconnects all poles with at least 3 mm contact separation.



#### WARNING Electrocutation

Ensure that the appliance is earthed.



#### Material losses

Observe the type plate. The specified rated voltage must match the mains voltage.

- ▶ Connect the power cable to the mains terminal.

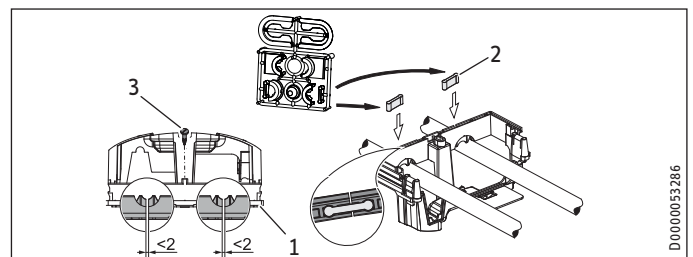

- 1 Lower back panel section
- 2 Connection piece in the standard delivery
- 3 Screw

If using threaded fittings on finished walls, the lower back panel section can also be installed after fitting the taps/valves. To do this, carry out the following steps:

- ▶ Cut open the lower section of the back panel.
- ▶ Fit the lower section of the back panel by bending it out at the sides and guiding it over the pipes.
- ▶ Insert the connection pieces into the lower section of the back panel from behind.
- ▶ Click the lower section of the back panel into place.

Secure the lower back panel section with a screw.

# INSTALLATION

## Commissioning



### Material losses

Do not bend the diffuser on the lower back panel when installing.

## 11. Commissioning

### 11.1 Preparation

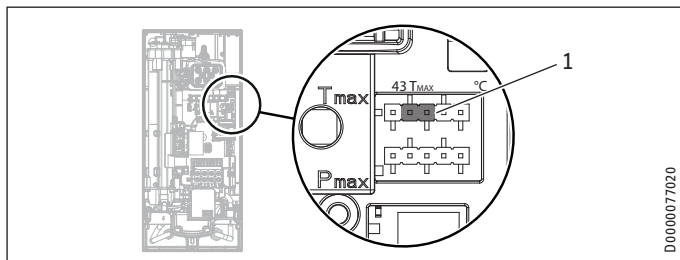

1 Jumper for anti-scalding protection setting

#### Internal anti-scalding protection via jumper slot

Jumper position	Description
43	For example, for shower mode, in nurseries, hospitals etc.
60	Factory setting
No jumper	Limited to 43 °C

- ▶ Install the anti-scalding protection setting jumper in the required position on the pin strip.



### CAUTION Burns

If the appliance is supplied with preheated water, the internal anti-scalding protection may be exceeded. In such cases, limit the temperature with an upstream central thermostatic valve (ZTA 3/4).

### 11.2 Initial start-up

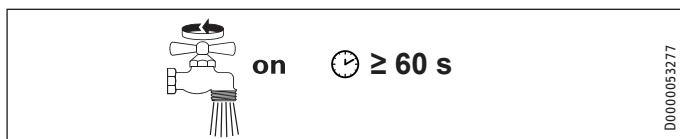

- ▶ Open and close all connected draw-off valves several times, until all air has been purged from the pipework and the appliance.
- ▶ Carry out a tightness check.

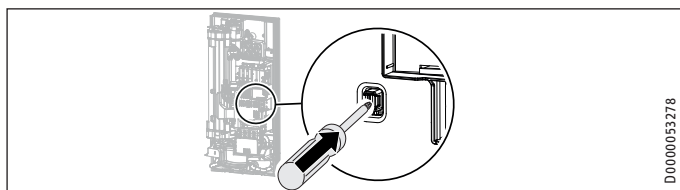

- ▶ Activate the safety switch by firmly pressing the reset button (the appliance is delivered with the safety switch disabled).

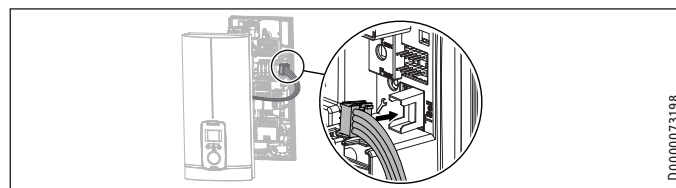

- ▶ Connect the programming unit connecting cable to the PCB.



### Note

For undersink installation, the appliance cover should be turned round for easier operation; see chapter "Alternative installation methods / Pivoting appliance cover".

#### Fit the appliance cover

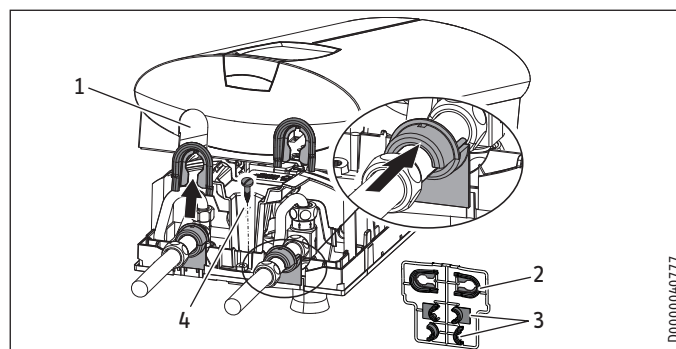

- 1 Pipe knock-out
- 2 Cover guides
- 3 Back panel guides
- 4 Fixing screw (not part of the standard delivery)

- ▶ Cleanly cut or break out the knock-out openings in the appliance cover. If necessary, use a file.



### Material losses

If you cut open the wrong knock-out in the appliance cover by mistake, you must use a new appliance cover.



### Note

You can compensate for a slight connection pipe offset using the tabs on the cover guides. If the connection pipes are offset, do not fit any back panel guides.

- ▶ When installing connection pipes without offset, break off the tabs on the cover guide pieces.
- ▶ Click the cover guides into place in the openings.
- ▶ Position the back panel guides on the extensions. Push them together. Then push the guide pieces against the back panel as far they will go.

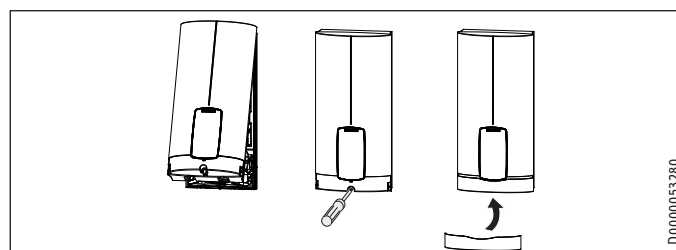

## INSTALLATION

### Appliance shutdown

- ▶ Pivot the appliance cover downwards. Check that the appliance cover is securely seated at both top and bottom.
- ▶ Secure the appliance cover with the screw.
- ▶ Fit the fascia to the appliance cover.



- ▶ Switch on the power supply.

#### 11.2.1 Appliance handover

- ▶ Explain the appliance function to users and familiarise them with its operation.
- ▶ Make the user aware of potential dangers, especially the risk of scalding.
- ▶ Hand over the instructions.

#### 11.3 Recommissioning



##### Material losses

To ensure that the bare wire heating system is not damaged following an interruption to the water supply, the appliance must be restarted taking the following steps.

- ▶ Disconnect the appliance from the power supply by removing the fuses/tripping the MCBs.
- ▶ Open the tap for a minimum of one minute until the appliance and its upstream cold water inlet line are free of air.
- ▶ Switch the power back ON.

## 12. Appliance shutdown

- ▶ Isolate all poles of the appliance from the power supply.
- ▶ Drain the appliance (see chapter "Installation / Maintenance / Draining the appliance").

## 13. Alternative installation methods

### Overview of the alternative types of installation

Electrical connection	IP rating
On unfinished walls, connected from above	IP 25
Unfinished walls, from below, short power cable	IP 25
Installation on finished walls	IP 24

Water connection	IP rating
Installation on unfinished walls	IP 25

Other	IP rating
Installation with offset tiles	IP 25
Pivoting appliance cover	IP 25



##### WARNING Electrocutation

Before any work on the appliance, disconnect all poles from the power supply.

### 13.1 Electrical connection from above on unfinished walls

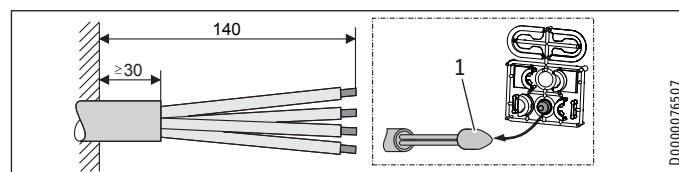

#### 1 Cable entry installation aid

- ▶ Prepare the power cable.

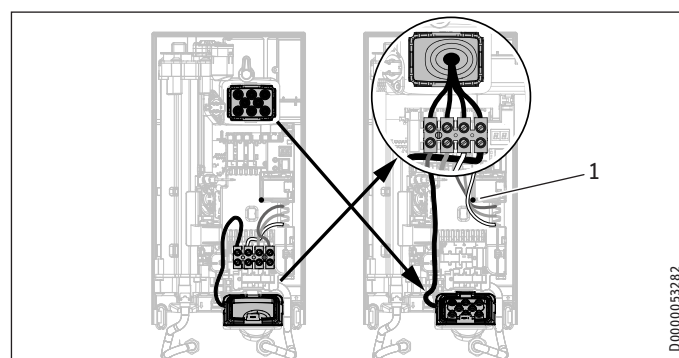

#### 1 Cable routing

- ▶ Reposition the mains terminal from the bottom to the top. To do this, undo the fixing screw. Turn the mains terminal with connecting cables 180° clockwise. Route the cable around the cable guide when doing so. Secure the mains terminal in place.
- ▶ Replace the cable grommets.
- ▶ Install the cable grommet downwards from above.
- ▶ Pull the cable grommet over the cable sheath of the power cable.
- ▶ Install the appliance on the threaded studs of the wall mounting bracket.
- ▶ Push the back panel firmly against the wall. Lock the fixing toggle by turning it 90° clockwise.
- ▶ Pull the cable grommets into the back panel, until both locking tabs engage.
- ▶ Connect the power cable to the mains terminal.



##### WARNING Electrocutation

The connecting wires must not protrude beyond the level of the mains terminal.

### 13.2 Electrical connection on unfinished walls with short power cable

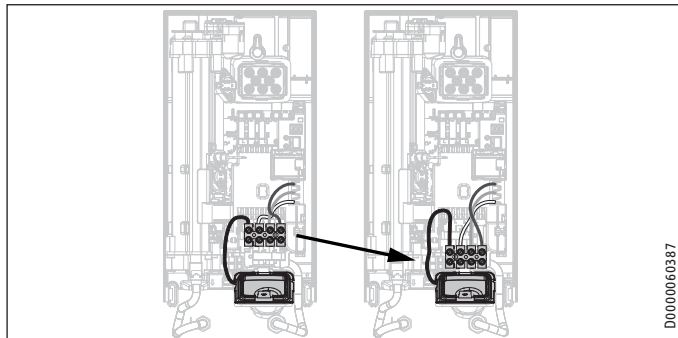

D0000060387

- Reposition the mains terminal further downwards. To do this, undo the fixing screw. Secure the mains terminal in place.

### 13.3 Electrical connection on finished walls



**Note**

This type of connection changes the IP rating of the appliance.

- Change the type plate. Cross out "IP 25" and mark the box "IP 24". Use a ballpoint pen to do this.

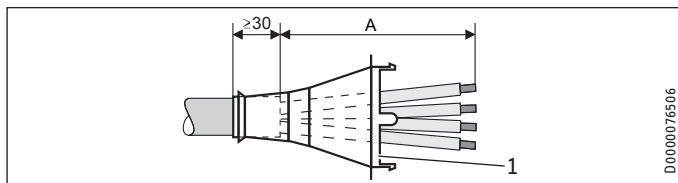

D0000076506

1 Cable grommet

Dimension A	Electrical connection on finished walls
160	Positioned in lower section of appliance
110	Positioned in upper section of appliance

160 Positioned in lower section of appliance

110 Positioned in upper section of appliance

- Prepare the power cable. Fit the cable grommet.



**Material losses**

If you break out the wrong knock-out in the back panel/appliance cover by mistake, you must use a new back panel/appliance cover.

- Cleanly cut and break out the required cable entries from the back panel and appliance cover (for the positions, see chapter "Specification / Dimensions and connections"). Deburr any sharp edges with a file.
- Route the power cable through the cable grommet.
- Connect the power cable to the mains terminal.



**Note**

If the appliance is rated IP 24, amend the appliance type plate.

- Cross out "IP 25" and mark the box "IP 24". Use a ballpoint pen to do this.

### 13.4 Connecting a load shedding relay

Install a load shedding relay in the distribution board in conjunction with other electric appliances, e.g. electric storage heaters. The relay responds when the instantaneous water heater starts.



**Material losses**

Connect the phase that switches the load shedding relay to the indicated terminal of the mains terminal in the appliance (see chapter "Specification / Wiring diagram").

### 13.5 Water installation on unfinished walls

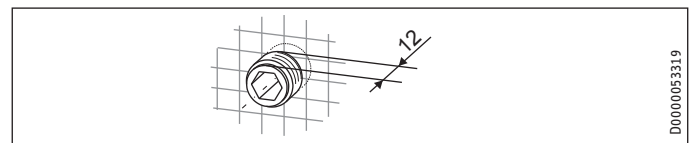

D0000053319

- Seal and screw in the twin connectors (not included in standard delivery).

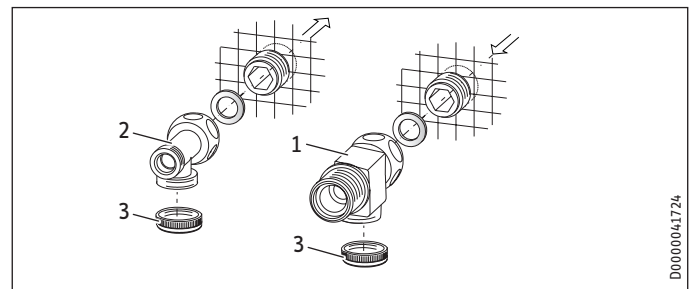

D0000041724

- 1 Tee for cold water
- 2 Tee for domestic hot water
- 3 Cap

- Fit the water connections.

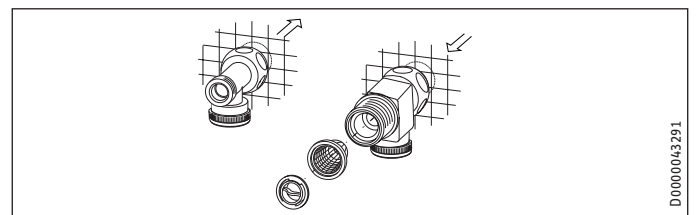

D0000043291

- Fit the strainer and the plastic profile washer in the tee for the cold water inlet.



**Material losses**

The strainer must be fitted for the appliance to function.

- When replacing the appliance, check that the strainer is present.

- Screw the connection pipes from the appliance to the tee.
- Open the shut-off valve in the cold water inlet line.

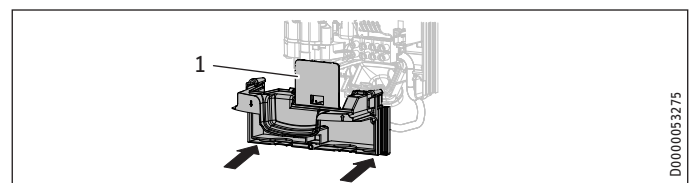

D0000053275

1 Diffuser on lower back panel

## INSTALLATION

### Alternative installation methods

- ▶ Fit the lower back panel section into the back panel. Check that both locking tabs are engaged.
- ▶ Align the mounted appliance by undoing the fixing toggle, aligning the power supply and back panel, and then re-tightening the fixing toggle. If the back panel does not sit flush against the wall, you can secure the appliance at the bottom with an additional screw.



#### Material losses

Do not bend the diffuser on the lower back panel when installing.

### 13.6 Wall mounting bracket when replacing appliance

An existing STIEBEL ELTRON wall mounting bracket may be used when replacing appliances (except for DHF instantaneous water heater), as long as the fixing screw is in the lower right position.

#### Replacing a DHF instantaneous water heater

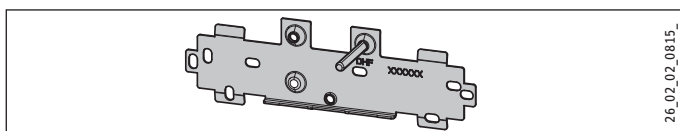

- ▶ Reposition the fixing screw on the wall mounting bracket (the securing screw has a self-tapping thread).
- ▶ Rotate the wall mounting bracket 180° and mount it on the wall (the DHF logo is then turned towards the reader).

### 13.7 Installation with offset tiles

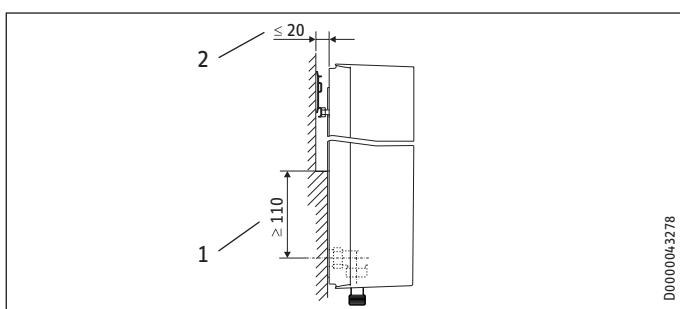

- 1 Minimum contact area of the appliance
- 2 Maximum tile offset

- ▶ Adjust the wall clearance. Lock the back panel in place using the fixing toggle (turn 90° clockwise).

### 13.8 Pivoting appliance cover

The appliance cover should be turned round for undersink installation.

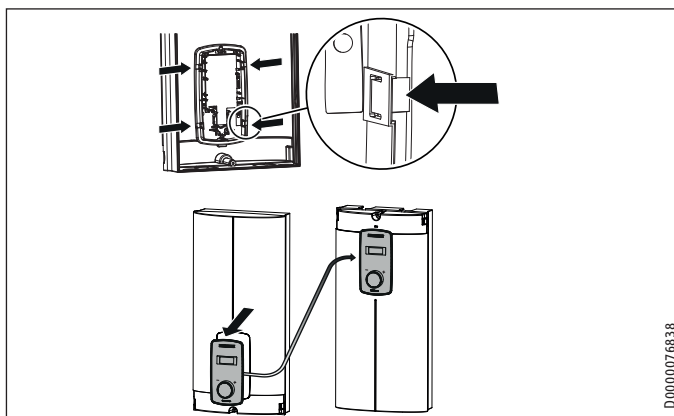

- ▶ Remove the programming unit from the appliance cover by pressing the locking hooks and removing the programming unit.
- ▶ Turn the appliance cover (not the appliance) and refit the programming unit. Push the programming unit home in parallel until all locking tabs engage. When engaging the locking tabs, apply counter pressure by pushing against the appliance cover from the inside.



#### WARNING Electrocutation

All 4 locking tabs on the programming unit must click into place. The locking tabs must be complete and undamaged. If the programming unit is not inserted correctly, protection of users against contact with live components cannot be ensured.

- ▶ Insert the connecting cable plug of the programming unit into the PCB (see chapter "Commissioning / Initial start-up").
- ▶ Hook the appliance cover in at the bottom. Pivot the appliance cover up to the back panel.
- ▶ Secure the appliance cover.
- ▶ Fit the cover on to the appliance cover.

### 13.9 Operation with preheated water

You can restrict the maximum inlet temperature by installing a central thermostatic valve.

### 14. Service information

#### Overview of connections

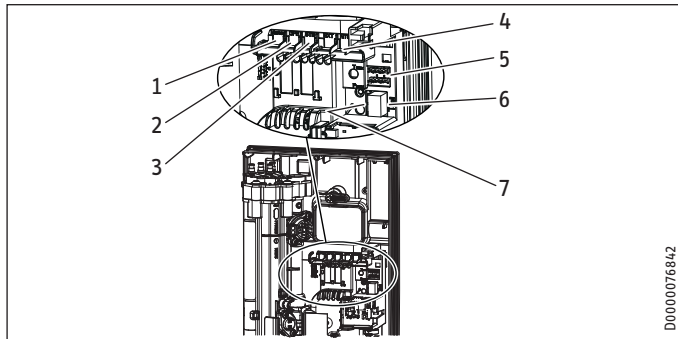

- 1 Flow limiter
- 2 Flow sensor

- 3 High limit safety cut-out, automatic reset
- 4 NTC sensor
- 5 Pin strip for anti-scalding protection
- 6 Programming unit plug-in position
- 7 Diagnostic traffic light

#### Appliance cover retainer

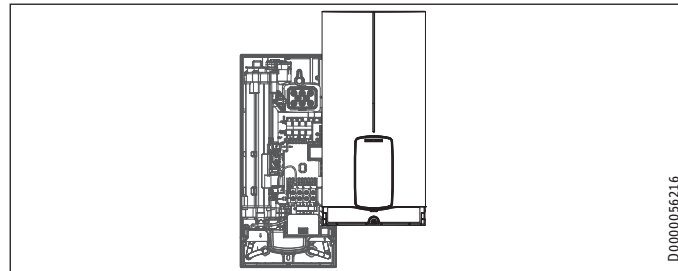

### 15. Troubleshooting



**WARNING** Electrocution  
To test the appliance, it must be connected to the power supply.



**Note**  
The diagnostic traffic light is displayed when water flows.

#### Indicator options for diagnostic traffic light (LED)

	Red	Illuminates in the event of a fault
	Yellow	Illuminates in heating mode/flashes when output restriction reached
	Green	Flashing: Appliance connected to power supply

Diagnostic traffic light	Fault	Cause	Remedy
No LED illuminates.	The appliance does not heat up.	There is no power supply. The PCB is faulty.	Check the fuse/MCB in your fuse box/distribution board. Replace the test assembly.
Green flashes, yellow off, red off	No DHW	The shower head / aerator are scaled up. The strainer in the cold water inlet is dirty. The flow meter is not plugged in. The flow meter is faulty. The PCB is faulty.	Descale or replace the shower head / aerator if necessary. Clean the strainer. Reconnect the connecting cable on the PCB. Replace the flow meter. Replace the test assembly.
Green flashes, yellow on, red off	The display is completely off.	Loose set value transducer cable between PCB and display. The programming unit connecting cable is faulty. The programming unit PCB is faulty.	Check the set value transducer cable and plug the cable into the programming unit and/or PCB. Check the connecting cable and replace if required. Check the programming unit and replace if required.
Green flashes, yellow on, red off	No DHW, the outlet temperature does not match the set value.	The downstream tap is faulty. Internal anti-scalding protection is activated. The heating system is faulty. The outlet detector is faulty. The PCB is faulty. Appliance is operating at its output limit.	Replace the faulty tap. Deactivate the internal anti-scalding protection. Replace the test assembly. Replace the outlet sensor. Replace the test assembly. Reduce the flow rate. Install the flow limiter.
Green flashes, yellow off, red on	No DHW, the outlet temperature does not match the set value.	The high limit safety cut-out is not enabled. The high limit safety cut-out is not connected. The high limit safety cut-out has tripped. The high limit safety cut-out is faulty.	Activate the safety switch. Reconnect the connecting cable on the PCB. Remedy the cause and activate the safety switch. Replace the high limit safety cut-out.

### 16. Maintenance



**WARNING Electrocutation**  
Before any work on the appliance, disconnect all poles from the power supply.

#### Draining the appliance

The appliance can be drained for maintenance work.



**WARNING Burns**  
Hot water may escape when you drain the appliance.

- ▶ Close the shut-off valve in the cold water inlet line.
- ▶ Open all draw-off valves.
- ▶ Undo the pipe connections from the appliance.
- ▶ Store the dismantled appliance in a room free from the risk of frost, as water residues remaining inside the appliance can freeze and cause damage.

#### Cleaning the strainer

If dirty, clean the strainer in the threaded cold water fitting. Close the shut-off valve in the cold water inlet line before removing, cleaning and refitting the strainer.

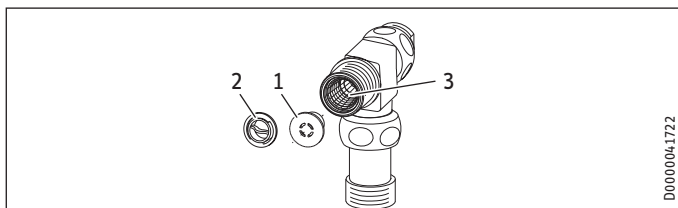

- 1 Flow limiter or
  - 2 Plastic profile washer
  - 3 Strainer
- ▶ Remove the plastic profile washer or flow limiter (selected during installation).
  - ▶ Remove the strainer and clean the components.
  - ▶ Fit the strainer and the plastic profile washer or the flow limiter.

### 17. Specification

#### 17.1 Dimensions and connections

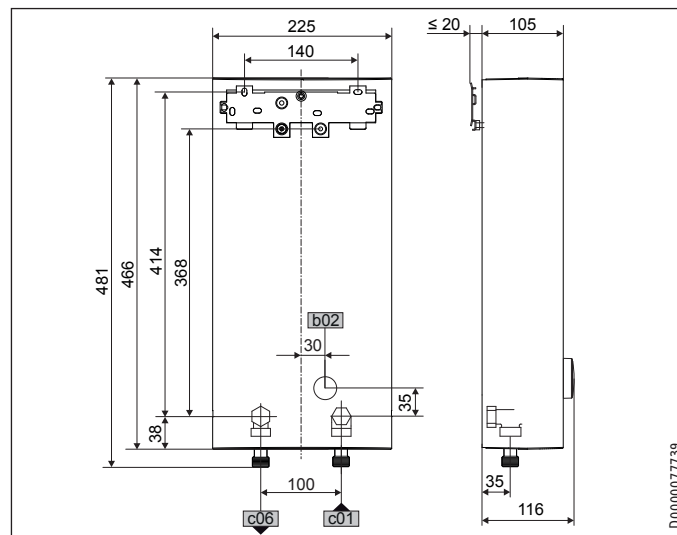

		DHB-E LCD AU
b02	Entry electrical cables I	Installation on unfinished walls
c01	Cold water inlet	Male thread G 1/2 A
c06	DHW outlet	Male thread G 1/2 A

#### Alternative connection options

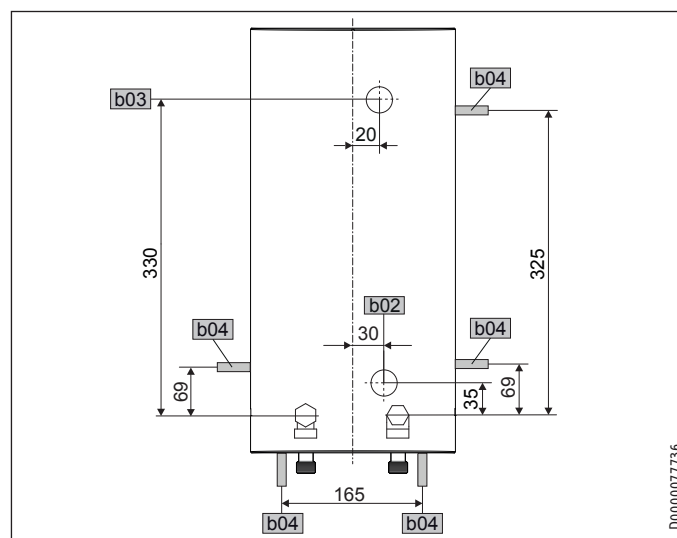

		DHB-E LCD AU
b02	Entry electrical cables I	Installation on unfinished walls
b03	Entry electrical cables II	Installation on unfinished walls
b04	Entry electrical cables III	Installation on finished walls

## 17.2 Wiring diagram

3/PE ~ 380-415 V

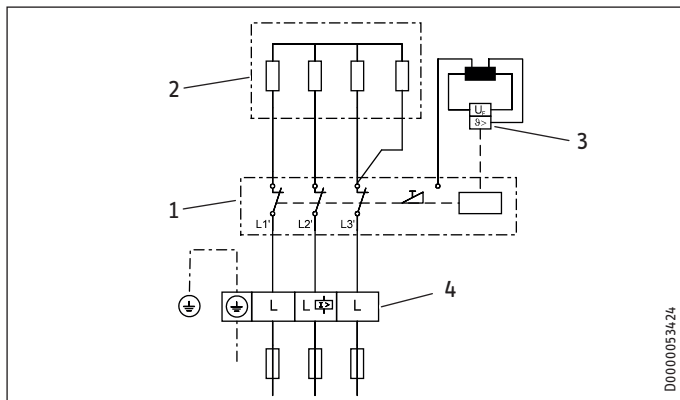

- 1 Power PCB with integral safety switch
- 2 Bare wire heating system
- 3 High limit safety cut-out
- 4 Mains terminal

### Priority control with LR 1-A

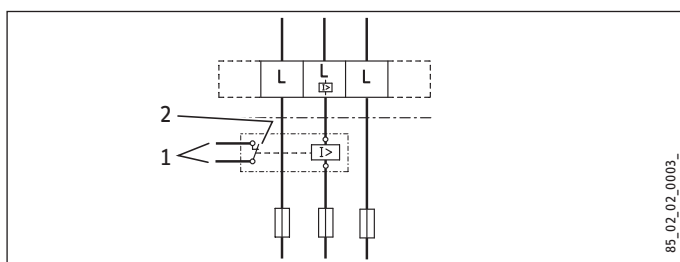

- 1 Control cable to the contactor of the second appliance (electric storage heater, for example)
- 2 Control contact drops out when switching the instantaneous water heater on.

## 17.3 Domestic hot water output

The DHW output is subject to the connected power supply, the appliance's connected load and the cold water inlet temperature. The rated voltage and rated output can be found on the type plate.

Connected load in kW			38 °C DHW output in L/min.			
Rated voltage			Cold water inlet temperature			
380 V	400 V	415 V	5 °C	10 °C	15 °C	20 °C
12.2			5.3	6.2	7.6	9.7
	13.5		5.8	6.9	8.4	10.7
		14.5	6.3	7.4	9.0	11.5
16.2			7.0	8.3	10.1	12.9
	18		7.8	9.2	11.2	14.3
		19.4	8.4	9.9	12.0	15.4
23.5			10.2	12.0	14.6	18.7
	26		11.3	13.3	16.1	20.6
		28	12.1	14.3	17.4	22.2

Connected load in kW			50 °C DHW output in L/min.			
Rated voltage			Cold water inlet temperature			
380 V	400 V	415 V	5 °C	10 °C	15 °C	20 °C
12.2			3.9	4.4	5.0	5.8
	13.5		4.3	4.8	5.5	6.4
		14.5	4.6	5.2	5.9	6.9
16.2			5.1	5.8	6.6	7.7
	18		5.7	6.4	7.3	8.6
		19.4	6.2	6.9	7.9	9.2
23.5			7.5	8.4	9.6	11.2
	26		8.3	9.3	10.6	12.4
		28	8.9	10.0	11.4	13.3

## 17.4 Application areas / Conversion table

Specific electrical resistance and specific electrical conductivity

Standard specification at 15 °C			20 °C			25 °C		
Resistance $\rho \geq$	Conductivity $\sigma \leq$	Unit	Resistance $\rho \geq$	Conductivity $\sigma \leq$	Unit	Resistance $\rho \geq$	Conductivity $\sigma \leq$	Unit
$\Omega\text{cm}$	$\text{mS/m}$	$\mu\text{S/cm}$	$\Omega\text{cm}$	$\text{mS/m}$	$\mu\text{S/cm}$	$\Omega\text{cm}$	$\text{mS/m}$	$\mu\text{S/cm}$
900	111	1111	800	125	1250	735	136	1361

## 17.5 Pressure drop

### Taps/valves

Tap pressure drop at a flow rate of 10 L/min	
Mono lever mixer tap, approx.	MPa 0.04 - 0.08
Thermostatic valve, approx.	MPa 0.03 - 0.05
Shower head, approx.	MPa 0.03 - 0.15

### Sizing the pipework

When calculating the size of the pipework, an appliance pressure drop of 0.1 MPa is recommended.

## 17.6 Fault conditions

In the event of a fault, loads up to 80 °C at a pressure of 1.0 MPa can occur briefly in the installation.

## 17.7 Test symbols

See type plate on the appliance

### Information for Australia/New Zealand:

Installation complies with standard AS/NZS 3500.4

# INSTALLATION Specification

## 17.8 Data table

		DHB-E 13 LCD AU			DHB-E 18 LCD AU			DHB-E 27 LCD AU		
		236747			236748			236749		
<b>Electrical data</b>										
Rated voltage	V	380	400	415	380	400	415	380	400	415
Rated output	kW	12.2	13.5	14.5	16.2	18	19.4	23.5	26	28
Rated current	A	18.5	19.5	20.2	24.7	26	27	35.6	37.7	38.9
Fuses	A	20	20	20	25	25	32	40	40	40
Frequency	Hz	50/60	50/60	50/-	50/60	50/60	50/-	50/-	50/-	50/-
Phases		3/PE			3/PE			3/PE		
Specific resistance $\rho_{15} \geq$	$\Omega$ cm	900			900			900		
Specific conductivity $\sigma_{15} \leq$	$\mu\text{S}/\text{cm}$	1111			1111			1111		
Max. mains impedance	$\Omega$	0.459	0.436	0.42	0.331	0.315	0.304	0.221	0.21	
<b>Versions</b>										
Heating system heat generator		Bare wire			Bare wire			Bare wire		
Adjustable connected load		-			-			-		
Temperature setting range	$^{\circ}\text{C}$	Off, 20-60			Off, 20-60			Off, 20-60		
Protection class		1			1			1		
Insulating block		Plastic			Plastic			Plastic		
Cover and back panel		Plastic			Plastic			Plastic		
IP rating		IP25			IP25			IP25		
Colour		White			White			White		
<b>Connections</b>										
Water connection		G 1/2 A			G 1/2 A			G 1/2 A		
<b>Application limits</b>										
Max. permissible pressure	MPa	1			1			1		
Max. inlet temperature for reheating	$^{\circ}\text{C}$	55			55			55		
<b>Values</b>										
Max. inlet temperature (e.g. pasteurisation)	$^{\circ}\text{C}$	70			70			70		
ON	l/min	>2.5			>2.5			>2.5		
Flow rate limit at	l/min	7.5			7.5			8.5		
Flow rate at 28 K	l/min	7.4 at 415 V			9.9 at 415 V			14.3 at 415 V		
Flow rate at 50 K	l/min	4.2 at 415 V			5.6 at 415 V			8.0 at 415 V		
Pressure drop for flow rate at 50 K (without flow limiter)	MPa	0.04			0.06			0.14		
Pressure drop for flow rate at 50 K (with flow limiter)	MPa	0.07			0.12			0.22		
<b>Hydraulic data</b>										
Nominal capacity	l	0.4			0.4			0.4		
<b>Dimensions</b>										
Height	mm	466			466			466		
Width	mm	225			225			225		
Depth	mm	116			116			116		
<b>Weights</b>										
Weight	kg	3.2			3.2			3.2		



### Note

The appliance conforms to IEC 61000-3-12.

## Environment and recycling

We would ask you to help protect the environment. After use, dispose of the various materials in accordance with national regulations.

## Who gives the warranty

1. The warranty is given by Stiebel Eltron (Aust) Pty Ltd (A.B.N. 82 066 271 083) of 6 Prohasky Street, Port Melbourne, Victoria, 3207 ("we", "us" or "our").

## The warranty

2. This warranty applies to the Stiebel Eltron Water Heaters - WaterMark Approved (the "unit") listed within this operating and installation guide manufactured after 1 May 2015.
3. Subject to the warranty exclusions we will repair or replace, at our absolute discretion, a faulty component in your unit free of charge if it fails to operate in accordance with its specifications during the warranty period.
4. If we repair or replace a faulty component to your unit under this warranty, the warranty period is not extended from the time of the repair or replacement.
5. The warranty period commences on the date of completion of the installation of the unit. Where the date of completion of installation is not known, then the warranty period will commence 2 months after the date of manufacture.
6. The warranty period for a unit used for domestic purposes is shown in the table below. Domestic purposes means that the unit is used in a domestic dwelling.

Component	Warranty period
All components	5 years from the date of completion of the installation of the unit.

7. The warranty period for a unit used for commercial purposes is shown in the table below. Commercial purposes means that the unit is used for a non-domestic purpose and includes but not limited to being used in a motel, hotel, mining camp or nursing home.

Component	Warranty period
All components	1 year from the date of completion of the installation of the unit.

## Your entitlement to make a warranty claim

8. You are entitled to make a warranty claim if:
  - 8.1. you own the unit or if you have the owner's consent to represent the owner of the unit;
  - 8.2. you contact us within a reasonable time of discovering the problem with the unit;

## How you make a warranty claim

9. To make a warranty claim you must provide us with the following information:
  - 9.1. The model number of the unit;
  - 9.2. A description of the problem with the unit;
  - 9.3. The name, address and contact details (such as phone number and e-mail address) of the owner;
  - 9.4. The address where the unit is installed and the location (e.g. in laundry);
  - 9.5. The serial number of the unit;
  - 9.6. The date of purchase of the unit and the name of the seller of the unit;
  - 9.7. The date of installation of the unit;
  - 9.8. A copy of the certificate of compliance when the unit was installed.
10. The contact details for you to make your warranty claim are:

Name: Stiebel Eltron (Aust) Pty Ltd  
 Address: 6 Prohasky Street, Port Melbourne, Victoria, 3207  
 Telephone: 1800 153 351  
 (8.00 am to 5.00 pm AEST Monday to Friday)  
 Contact person: Customer Service Representative  
 E-mail: service@stiebel.com.au

11. We will arrange a suitable time with you to inspect and test the unit.

## Warranty exclusions

12. We may reject your warranty claim if:
  - 12.1. The unit was not installed by registered and qualified tradespeople.
  - 12.2. The unit was not installed and commissioned:
    - (a) in Australia;
    - (b) in accordance with the Operating and Installation Guide; and
    - (c) in accordance with the relevant statutory and local requirements of the State or Territory in which the unit is installed.
  - 12.3. The unit has not been operated or maintained in accordance with the Operating and Installation Guide.
  - 12.4. The unit does not bear its original Serial Number for Rating Label.
  - 12.5. The unit was damaged by any or any combination of the following:
    - (a) normal fair wear and tear;
    - (b) connection to an incorrect water supply;
    - (c) connection to water from a bore, dam or swimming pool;
    - (d) connection to an incorrect power supply;
    - (e) connection to faulty equipment, such as damaged valves;
    - (f) foreign matter in the water supply, such as sludge or sediment;
    - (g) corrosive elements in the water supply;
    - (h) accidental damage;
    - (i) act of God, including damage by flood, storm, fire, lightning strike and the like;
    - (j) excessive water pressure, negative water pressure (partial vacuum) or water pressure pulsation.
  - 12.6. The unit was damaged before it was installed e.g. it was damaged in transit.
  - 12.7. An unauthorised person has modified, serviced, repaired or attempted to repair the unit without our consent.
  - 12.8. Non genuine parts other than those manufactured or approved by us have been used on the unit.
13. We may charge you:
  - 13.1. for any additional transport costs if the unit is installed more than 30 kilometres from our closest authorised service technician.
  - 13.2. for the extra time it takes our authorised service technician to access the unit for inspection and testing if it is not sited in accordance with the Operating and Installation Guide and not readily accessible for inspection.
  - 13.3. for any extra costs of our authorised service technician to make the unit safe for inspection.
14. You must ensure that access to the unit by our authorised service technician is safe and free from obstruction.
15. Our authorised service technician may refuse to inspect and test the unit until you provide safe and free access to it, at your cost.
16. If we reject your warranty claim in accordance with clause 12, we may charge you for our authorised service technician's labour costs to inspect and test the unit.
17. In order to properly test the unit we may remove it to another location for testing.

## Australian Consumer Law

18. Our goods come with guarantees that cannot be excluded under the Australian Consumer Law. You are entitled to a replacement or refund for a major failure and compensation for any other reasonably foreseeable loss or damage. You are also entitled to have the goods repaired or replaced if the goods fail to be of acceptable quality and the failure does not amount to a major failure.
19. The Stiebel Eltron warranty for the unit is in addition to any rights and remedies you may have under the Australian Consumer Law.

## Deutschland

STIEBEL ELTRON GmbH & Co. KG  
Dr.-Stiebel-Straße 33 | 37603 Holzminden  
Tel. 05531 702-0 | Fax 05531 702-480  
info@stiebel-eltron.de  
www.stiebel-eltron.de

## Verkauf

Tel. 05531 702-110 | Fax 05531 702-95108 | info-center@stiebel-eltron.de

## Kundendienst

Tel. 05531 702-111 | Fax 05531 702-95890 | kundendienst@stiebel-eltron.de

## Ersatzteilverkauf

Tel. 05531 702-120 | Fax 05531 702-95335 | ersatzteile@stiebel-eltron.de

## Australia

STIEBEL ELTRON Australia Pty. Ltd.  
6 Prohasky Street | Port Melbourne VIC 3207  
Tel. 03 9645-1833 | Fax 03 9645-4366  
info@stiebel.com.au  
www.stiebel.com.au

## Austria

STIEBEL ELTRON Ges.m.b.H.  
Gewerbegebiet Neubau-Nord  
Margaritenstraße 4 A | 4063 Hörsching  
Tel. 07221 74600-0 | Fax 07221 74600-42  
info@stiebel-eltron.at  
www.stiebel-eltron.at

## Belgium

STIEBEL ELTRON bvba/sprl  
't Hofveld 6 - D1 | 1702 Groot-Bijgaarden  
Tel. 02 42322-22 | Fax 02 42322-12  
info@stiebel-eltron.be  
www.stiebel-eltron.be

## China

STIEBEL ELTRON (Guangzhou) Electric  
Appliance Co., Ltd.  
Rm 102, F1, Yingbin-Yihao Mansion, No. 1  
Yingbin Road  
Panyu District | 511431 Guangzhou  
Tel. 020 39162209 | Fax 020 39162203  
info@stiebeleltron.cn  
www.stiebeleltron.cn

## Czech Republic

STIEBEL ELTRON spol. s r.o.  
K Hájům 946 | 155 00 Praha 5 - Stodůlky  
Tel. 251116-111 | Fax 235512-122  
info@stiebel-eltron.cz  
www.stiebel-eltron.cz

## Finland

STIEBEL ELTRON OY  
Kapinakuja 1 | 04600 Mäntsälä  
Tel. 020 720-9988  
info@stiebel-eltron.fi  
www.stiebel-eltron.fi

## France

STIEBEL ELTRON SAS  
7-9, rue des Selliers  
B.P 85107 | 57073 Metz-Cédex 3  
Tel. 0387 7438-88 | Fax 0387 7468-26  
info@stiebel-eltron.fr  
www.stiebel-eltron.fr

## Hungary

STIEBEL ELTRON Kft.  
Gyár u. 2 | 2040 Budaörs  
Tel. 01 250-6055 | Fax 01 368-8097  
info@stiebel-eltron.hu  
www.stiebel-eltron.hu

## Japan

NIHON STIEBEL Co. Ltd.  
Kowa Kawasaki Nishiguchi Building 8F  
66-2 Horikawa-Cho  
Saiwai-Ku | 212-0013 Kawasaki  
Tel. 044 540-3200 | Fax 044 540-3210  
info@nihonstiebel.co.jp  
www.nihonstiebel.co.jp

## Netherlands

STIEBEL ELTRON Nederland B.V.  
Daviottenweg 36 | 5222 BH 's-Hertogenbosch  
Tel. 073 623-0000 | Fax 073 623-1141  
info@stiebel-eltron.nl  
www.stiebel-eltron.nl

## Poland

STIEBEL ELTRON Polska Sp. z O.O.  
ul. Działkowa 2 | 02-234 Warszawa  
Tel. 022 60920-30 | Fax 022 60920-29  
biuro@stiebel-eltron.pl  
www.stiebel-eltron.pl

## Russia

STIEBEL ELTRON LLC RUSSIA  
Urzhumskaya street 4,  
building 2 | 129343 Moscow  
Tel. 0495 7753889 | Fax 0495 7753887  
info@stiebel-eltron.ru  
www.stiebel-eltron.ru

## Slovakia

TATRAMAT - ohrievače vody s.r.o.  
Hlavná 1 | 058 01 Poprad  
Tel. 052 7127-125 | Fax 052 7127-148  
info@stiebel-eltron.sk  
www.stiebel-eltron.sk

## Switzerland

STIEBEL ELTRON AG  
Industrie West  
Gass 8 | 5242 Lupfig  
Tel. 056 4640-500 | Fax 056 4640-501  
info@stiebel-eltron.ch  
www.stiebel-eltron.ch

## Thailand

STIEBEL ELTRON Asia Ltd.  
469 Moo 2 Tambol Klong-Jik  
Amphur Bangpa-In | 13160 Ayutthaya  
Tel. 035 220088 | Fax 035 221188  
info@stiebeleltronasia.com  
www.stiebeleltronasia.com

## United Kingdom and Ireland

STIEBEL ELTRON UK Ltd.  
Unit 12 Stadium Court  
Stadium Road | CH62 3RP Bromborough  
Tel. 0151 346-2300 | Fax 0151 334-2913  
info@stiebel-eltron.co.uk  
www.stiebel-eltron.co.uk

## United States of America

STIEBEL ELTRON, Inc.  
17 West Street | 01088 West Hatfield MA  
Tel. 0413 247-3380 | Fax 0413 247-3369  
info@stiebel-eltron-usa.com  
www.stiebel-eltron-usa.com

**STIEBEL ELTRON**



Irrtum und technische Änderungen vorbehalten! | Subject to errors and technical changes! | Sous réserve d'erreurs et de modifications techniques! | Onder voorbehoud van vergissingen en technische wijzigingen! | Salvo error o modificación técnica! | Excepto erro ou alteração técnica | Zastrzeżone zmiany techniczne i ewentualne błędy | Omyly a technické změny jsou vyhrazeny! | A muszaki változtatások és tévedések jogát fenntartjuk! | Отсутствие ошибок не гарантируется. Возможны технические изменения. | Chyby a technické zmeny sú vyhradené!

Stand 9147