

# OPERATION AND INSTALLATION

Air | water heat pump

- » WPL 13 E
- » WPL 18 E
- » WPL 23 E
- » WPL 13 cool
- » WPL 18 cool
- » WPL 23 cool

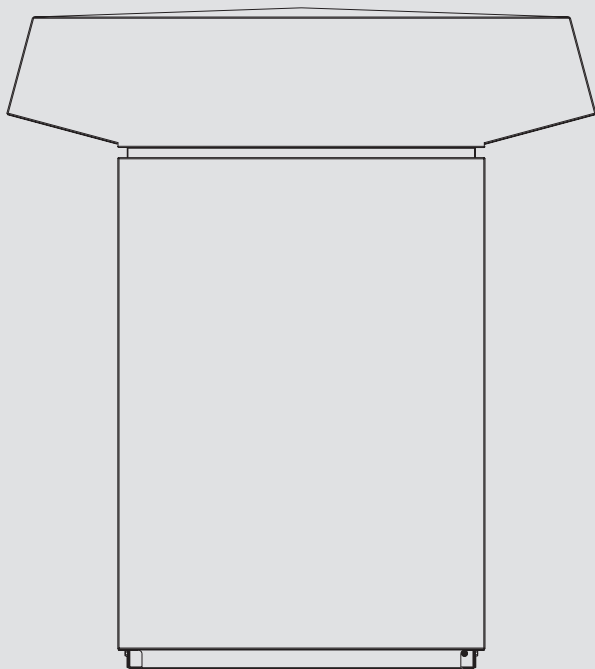

**STIEBEL ELTRON**

# CONTENTS

## SPECIAL INFORMATION

### OPERATION

<b>1. General information</b>	<b>3</b>
1.1 Relevant documents	3
1.2 Safety instructions	3
1.3 Other symbols in this documentation	4
1.4 Units of measurement	4
1.5 Standardised output data	4
<b>2. Safety</b>	<b>4</b>
2.1 Intended use	4
2.2 Safety instructions	4
2.3 Test symbols	4
<b>3. Appliance description</b>	<b>5</b>
3.1 Function	5
<b>4. Settings</b>	<b>5</b>
<b>5. Maintenance and care</b>	<b>5</b>
<b>6. Troubleshooting</b>	<b>6</b>

### INSTALLATION

<b>7. Safety</b>	<b>7</b>
7.1 General safety instructions	7
7.2 Instructions, standards and regulations	7
7.3 Operation of the appliance in buildings with combustion equipment	7
<b>8. Appliance description</b>	<b>7</b>
8.1 Standard delivery	7
8.2 Required accessories	7
8.3 Additional accessories	7
<b>9. Preparations</b>	<b>8</b>
9.1 Sound emissions	8
9.2 Minimum clearances	8
9.3 Preparation of the installation site	9
9.4 Electrical installation	10
9.5 Buffer cylinder	11
<b>10. Installation</b>	<b>11</b>
10.1 Transport	11
10.2 Siting and connecting the appliance	11
10.3 Heating water connection	13
10.4 Second heat source	13
10.5 Filling the heating system	14
10.6 Minimum flow rate	14
10.7 Condensate drain	15
10.8 Checking the draining of condensate	16
10.9 High limit safety cut-out for underfloor heating systems	16
<b>11. Power supply</b>	<b>16</b>
11.1 Control panel	16
<b>12. Fitting casing components</b>	<b>18</b>
12.1 Outdoor installation	18
12.2 Indoor installation	19
<b>13. Commissioning</b>	<b>21</b>
13.1 Check before commissioning the heat pump manager	21
13.2 Commissioning the heat pump manager	22
13.3 Initial start-up	22

13.4 Settings	23
<b>14. Appliance shutdown</b>	<b>23</b>
14.1 Standby mode	23
14.2 Power interruption	23
<b>15. Appliance handover</b>	<b>24</b>
<b>16. Troubleshooting</b>	<b>24</b>
16.1 Controls on the IWS	24
16.2 Resetting the high limit safety cut-out	24
16.3 Fan noise	25
<b>17. Maintenance</b>	<b>25</b>
17.1 Clean condensate pan and drain	25
<b>18. Specification</b>	<b>26</b>
18.1 Dimensions and connections	26
18.2 Wiring diagram	28
18.3 Output diagrams	30
18.4 Data table	36

### GUARANTEE

### ENVIRONMENT AND RECYCLING

# SPECIAL INFORMATION OPERATION

- The appliance may be used by children aged 8 and older and persons with reduced physical, sensory or mental capabilities or a lack of experience and know-how, provided that they are supervised or they have been instructed on how to use the appliance safely and have understood the potential risks. Children must never play with the appliance. Children must never clean the appliance or perform user maintenance unless they are supervised.
- The connection to the power supply must be in the form of a permanent connection. Ensure the appliance can be separated from the power supply by an isolator that disconnects all poles with at least 3 mm contact separation.
- Maintain the minimum clearances to ensure trouble-free operation of the appliance and facilitate maintenance work.
- Maintenance work, such as checking the electrical safety, must only be carried out by a qualified contractor.
- We recommend an annual inspection (to establish the current condition of the system), and maintenance by a qualified contractor if required (to return the system to its original condition).
- Never interrupt the power supply, even outside the heating season. The system's active frost protection is not guaranteed if the power supply is interrupted.
- The heat pump manager automatically switches the heat pump to summer or winter mode.
- If the heat pump is completely switched off and there is a risk of frost, drain the system on the water side.

## 1. General information

The chapters "Special information" and "Operation" are intended for both users and qualified contractors.

The chapter "Installation" is intended for qualified contractors.



### Note

Read these instructions carefully before using the appliance and retain them for future reference. Pass on the instructions to a new user if required.

### 1.1 Relevant documents



Operating and installation instructions for the WPM heat pump manager



Operating and installation instructions for system components

### 1.2 Safety instructions

#### 1.2.1 Structure of safety instructions



#### KEYWORD Type of risk

Here, possible consequences are listed that may result from failure to observe the safety instructions.

► Steps to prevent the risk are listed.

#### 1.2.2 Symbols, type of risk

Symbol	Type of risk
	Injury
	Electrocution

#### 1.2.3 Keywords

KEYWORD	Meaning
DANGER	Failure to observe this information will result in serious injury or death.
WARNING	Failure to observe this information may result in serious injury or death.
CAUTION	Failure to observe this information may result in non-serious or minor injury.

### 1.3 Other symbols in this documentation



#### Note

General information is identified by the adjacent symbol.  
► Read these texts carefully.

Symbol	Meaning
	Material losses (appliance damage, consequential losses and environmental pollution)
	Appliance disposal

► This symbol indicates that you have to do something. The action you need to take is described step by step.

### 1.4 Units of measurement



#### Note

All measurements are given in mm unless stated otherwise.

### 1.5 Standardised output data

Information on determining and interpreting the specified standardised output data.

#### 1.5.1 Standard: EN 14511

The output data specifically mentioned in text, diagrams and technical datasheets has been calculated according to the test conditions of the standard shown in the heading of this section.

Generally, these standardised test conditions will not fully meet the conditions found at the installation site of the system user.

Depending on the chosen test method and the extent to which this method deviates from the conditions defined in the norm shown in the heading of this section, any deviations can have a considerable impact.

Additional factors that have an influence on the test values are the measuring equipment, the system configuration, the age of the system and the flow rates.

A confirmation of the specified output data can only be obtained if the test conducted for this purpose is also performed in accordance with the conditions defined in the norm shown in the heading of this section.

## 2. Safety

### 2.1 Intended use

The WPL E appliance is designed for central heating within the application limits given in the specification.

The WPL cool appliance is designed for central heating and cooling within the application limits given in the specification.

The appliance is intended for domestic use. It can be used safely by untrained persons. The appliance can also be used in non-domestic environments, e.g. in small businesses, as long as it is used in the same way.

Any other use beyond that described shall be deemed inappropriate. Observation of this document is also part of the correct use of the unit.

### 2.2 Safety instructions

Observe the following safety instructions and regulations.

- Only qualified contractors are permitted to carry out electrical work and the installation of the heating circuit.
- The qualified contractor is responsible for adherence to all applicable regulations during installation and commissioning.
- The appliance should only be operated once it is fully installed and all safety equipment has been fitted.
- Protect the appliance from dust and dirt during building work.



#### WARNING Injury

The appliance may be used by children over 8 years of age and persons with reduced physical, sensory or mental capabilities or a lack of experience and expertise, provided that they are supervised or they have been instructed on how to use the appliance safely and have understood the potential risks. Children must never play with the appliance. Children must never clean the appliance or perform user maintenance unless they are supervised.



#### WARNING Injury

► For safety reasons, only operate the appliance with the casing closed.

### 2.3 Test symbols

See type plate on the appliance.



### 3. Appliance description

The appliance is an air | water heat pump that operates as a heating heat pump. The appliance extracts heat from the outdoor air at a low temperature level and transfers it to the heating water at a higher temperature level. The heating water can be heated up to a flow temperature of 60 °C.

With the appropriate accessories, this appliance may be installed internally or externally.

The appliance is equipped with an electric emergency/booster heater (DHC). If the dual mode point is undershot in mono mode operation, the electric emergency/booster heater is activated to safeguard heating operation and the provision of high DHW temperatures. In such a case in mono energetic operation, the electric emergency/booster heater is activated as a booster heater.

#### Additional features

- Suitable for underfloor and radiator heating systems
- Preferred for low temperature heating systems
- Still extracts heat from the outdoor air at - 20 °C outside temperature
- Corrosion-protected, external casing made from hot-dipped galvanised sheet steel plus stove-enamelled finish
- Comprises all components and safety equipment required for operation
- Filled with non-combustible safety refrigerant



#### Note

To control the heating system, you will need the WPM heat pump manager.

### 3.1 Function

#### 3.1.1 Heating

Heat is extracted from the outdoor air via the heat exchanger (evaporator) on the air side. The refrigerant evaporates and is compressed by a compressor. This process requires electrical energy.

The refrigerant is then at a higher temperature level and transfers the heat drawn from the air to the heating system via an additional heat exchanger (condenser). The refrigerant then expands and the cycle begins again.

At air temperatures below approx. 7 °C, the humidity in the air condenses as hoarfrost on the evaporator fins. This hoarfrost is automatically defrosted. Water created by this defrosting process collects in the defrost pan and is drained off via a hose.

During the defrost cycle, the fan is switched off and the heat pump circuit is reversed. The heat required for defrosting is drawn from the buffer cylinder. The heat pump automatically reverts to heating mode at the end of the defrost cycle.



#### Material losses

In dual mode operation, return water from the second heat generator may flow through the heat pump. Please note that the return temperature must be no higher than 60 °C.

#### 3.1.2 Cooling (WPL cool only)



#### Material losses

The heat pump is not suitable for continuous, year-round cooling.

- ▶ Observe the application limits (see chapter "Specification / Data table").

Rooms are cooled by reversing the heat pump circuit. Heat is extracted from the heating water and the evaporator transfers this heat to the outdoor air.

Area cooling requires the installation of the FEK remote control unit in a reference room to capture the relative humidity and the room temperature as part of dew point monitoring.

#### Heat pump application limit

The heat pump is switched off if the outside temperature falls below the selected lower application limit for cooling (LIMIT COOLING parameter).

## 4. Settings

The appliance is controlled with the heat pump manager and requires no special operation.

- ▶ Please observe the heat pump manager operating and installation instructions.

## 5. Maintenance and care



#### Material losses

Maintenance work, such as checking the electrical safety, must only be carried out by a qualified contractor.



#### Note

- ▶ Keep the air discharge and intake apertures free from snow and leaves.

A damp cloth is sufficient for cleaning all plastic and sheet metal parts. Never use abrasive or corrosive cleaning agents.

- ▶ Protect the appliance from dust and dirt during building work.
- ▶ Every month, check that the condensate drain is working correctly (visual inspection). When doing so, check for water collecting below or next to the appliance. For further information, see chapter "Troubleshooting".

We recommend a regular inspection (to establish the current condition of the system), and maintenance by a qualified contractor if required (to return the system to its original condition).

## 6. Troubleshooting

Fault	Cause	Remedy
There is no hot water or the heating system remains cold.	No power at the appliance.	Check the fuses/MCBs in your distribution board. Replace the fuses/reset the MCBs if required. Notify your qualified contractor if the fuses/MCBs blow/trip again.
Water is leaking from the appliance.	The condensate drain may be blocked.	Call your contractor to have the condensate drain cleaned out.
Indoor installation: Condensate is collecting on the outside of the appliance or on the air hoses.	The drying out phase of the building is not yet complete.	This condensate should no longer form on the appliance after the house is approx. two years old, providing the room is sufficiently well ventilated and dehumidified.
	The relative humidity in the air is high ( $\geq 60\%$ ).	A change in weather conditions should no longer cause condensation to form on the appliance.
	The appliance is sited in a damp room. Damp rooms are those where humidity in the air is high. They may, for example, be used for drying laundry.	Ensure that the room is adequately ventilated and dehumidified. If necessary, hang your laundry in a different room. Use a vented tumble dryer. Please note that condenser tumble dryers do not reduce the level of humidity in the air.
Outdoor installation: Condensate is collecting on the outside of the appliance.	The air hoses are incorrectly fitted or poorly sealed. Cold air is escaping.	Check that the air hoses are correctly fitted and sealed. If necessary, contact your qualified contractor.
	The heat pump is extracting heat from the outdoor air to heat the building. This can cause the humidity in the outdoor air to accumulate as dew or frost on the cooled heat pump casing. This is not a defect.	



**Note**

Even when the condensate is draining away correctly, expect water to drip from the appliance onto the floor.

If you cannot remedy the fault, notify your qualified contractor. To facilitate and speed up your enquiry, please provide the serial number from the type plate (000000-0000-000000).

**Sample type plate**

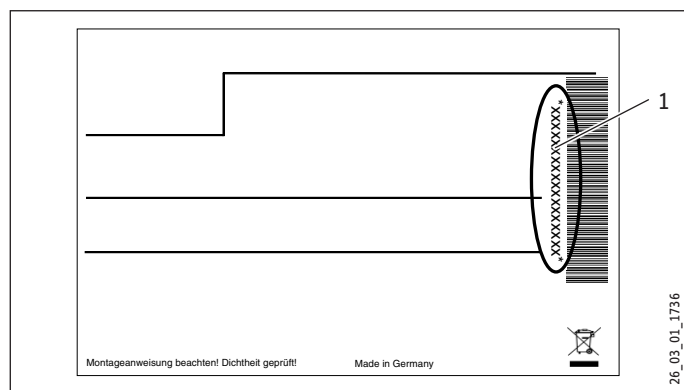

1 Number on the type plate

# INSTALLATION

## 7. Safety

Only a qualified contractor should carry out installation, commissioning, maintenance and repair of the appliance.

### 7.1 General safety instructions

We guarantee trouble-free function and operational reliability only if original accessories and spare parts intended for the appliance are used.

### 7.2 Instructions, standards and regulations



**Note**

Observe all applicable national and regional regulations and instructions.

### 7.3 Operation of the appliance in buildings with combustion equipment

As the appliance can produce negative pressure in the installation room, we recommend using a tightly sealing door between the installation room and the living space for operation with combustion equipment.

If, due to its use, the installation room is connected to the extract air system, you must also allow for a supply air valve in the installation room in this particular case to prevent any further increase in the negative pressure in the installation room. The negative pressure created by the appliance in the installation room is heavily influenced by the pressure drop in the outdoor air line. For this reason, the outdoor air line in particular should be as short as possible.

## 8. Appliance description

For outdoor installation the appliance offers additional frost protection of the heating water pipes. The integral frost protection circuit starts the heating circulation pump in the heat pump circuit automatically at +8 °C condenser temperature, and in doing so ensures circulation in all water-filled sections.

The heat pump starts automatically when the temperature in the heat pump circuit drops below +5 °C.

### 8.1 Standard delivery

The casing components for the appliance are delivered in a separate packing unit.

#### 8.1.1 Standard appliance

- Type plate

#### 8.1.2 Casing components – outdoor installation

- Hood – outdoor installation
- Front panel
- Back panel
- Pipe bend for heating circuit flow
- Pipe bend for heating circuit return

#### 8.1.3 Casing components for indoor installation

- Cover - indoor installation
- Front panel
- Back panel
- Pipe bend for heating circuit return

## 8.2 Required accessories

### 8.2.1 Outdoor installation

- WPM 3 heat pump manager
- Accessories – outdoor installation
- Pressure hoses SD 25 or SD 32

### 8.2.2 Indoor installation

- WPM 3 heat pump manager
- Accessories – indoor installation
- Pressure hoses SD 25 or SD 32

### 8.2.3 Cooling

- Remote control for heating systems FEK

## 8.3 Additional accessories

### 8.3.1 Outdoor installation

- Remote control for FE7 heating systems
- Water softening fitting HZEA
- SP cool distributor strip
- Internet Service Gateway ISG

### 8.3.2 Indoor installation

- Air hose DN 560 x 4 m
- Hose connection panel 560
- Wall outlet AWG 560 H-SR
- Wall outlet AWG 560 H-GL
- Wall outlet AWG 560 V-SR
- Wall outlet AWG 560 V-GL
- Wall outlet AWG 560 L
- Wall outlet AWG 600 L
- Remote control for FE7 heating systems
- Condensate pump PK 10
- Water softening fitting HZEA
- SP cool distributor strip
- Internet Service Gateway ISG

### 9. Preparations

#### 9.1 Sound emissions

The appliance is louder on the air intake and air discharge sides than on the two enclosed sides. Take the following information into account when selecting the installation location.



#### Note

For details regarding the sound power level, see chapter "Specification / Data table".

##### 9.1.1 Sound emissions for outdoor installation

- Lawn areas and shrubs help reduce the spread of noise.
- Noise propagation can also be reduced through dense palisades or similar.
- ▶ Ensure that the entire appliance frame is in full contact with the substrate. Uneven substrates can increase sound emissions.
- ▶ Ensure that the air intake direction is the same as the dominant wind direction. Air should not be drawn in against the wind.
- ▶ Ensure that the air intake and air discharge are never directed towards noise-sensitive rooms of the house, e.g. bedrooms, or neighbouring houses.
- ▶ Avoid installation on large, echoing floor areas, e.g. tiled floors.
- ▶ Avoid installation between reflective building walls. Reflecting building walls can increase the noise level.

##### 9.1.2 Sound emissions for indoor installation

- Never install on joists.
- ▶ Ensure that the entire appliance frame is in full contact with the substrate. Uneven substrates can increase sound emissions.
- ▶ Never install the appliance directly below or next to a living room or bedroom.
- ▶ Never direct the air intake and discharge apertures in external walls towards neighbouring windows or living rooms/ bedrooms.
- ▶ Protect pipe outlets through walls and ceilings with anti-vibration insulation.

#### 9.2 Minimum clearances

##### 9.2.1 Outdoor installation

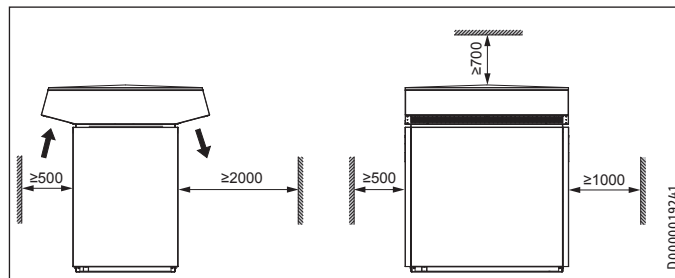

- ▶ Maintain the minimum clearances to ensure trouble-free operation of the appliance and facilitate maintenance work.

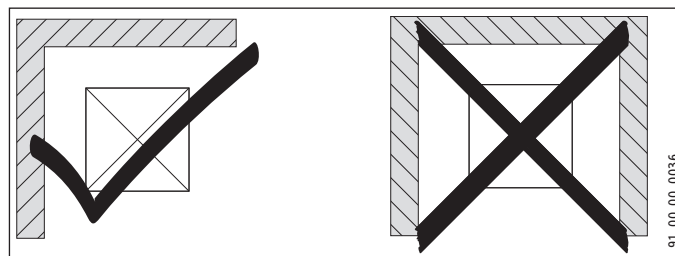

- ▶ Never install the appliance in a recess. Two sides of the appliance must remain exposed.
- ▶ In order to prevent air "short circuits", maintain the minimum clearances in the case of surrounding structures and in particular in the case of cascades. Maintain the flow rate on the heat source side (see chapter "Specification / data table").



#### Material losses

Please note that both the flow of outdoor air into the appliance, and the flow of exhaust air from the appliance must be unimpeded.

If the air intake and discharge of the appliance are obstructed by surrounding objects, this may cause a thermal short-circuit.

- ▶ Ensure that the appliance is not fully enclosed by objects such as buildings, walls or fences.

If the air discharge side of the appliance faces the wall of a house, the cool air from the air discharge may cause condensate to form on this wall.



#### Material losses

The air flow rate through the appliance must not fall below the minimum level. If the air flow rate falls below the minimum level, trouble-free operation of the appliance is not guaranteed.

- ▶ Ensure that the minimum air flow rate is maintained (see chapter "Specification / Data table").

# INSTALLATION

## Preparations

### 9.2.2 Indoor installation

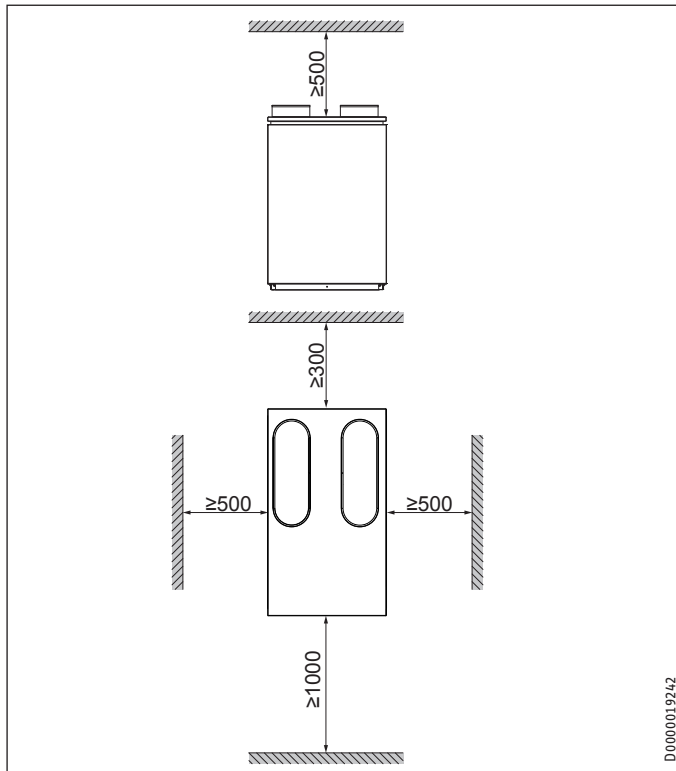

- ▶ Maintain the minimum clearances to ensure trouble-free operation of the appliance and facilitate maintenance work.

### 9.3 Preparation of the installation site

#### General information

- ▶ See chapter "Sound emissions".
- ▶ Ensure that the appliance is accessible from all sides.
- ▶ Ensure that the substrate is level, even, solid and permanent.

### 9.3.1 Outdoor installation

- ▶ Provide a recess (space) in the base to enable supply pipes/cables to be routed into the appliance from below.

#### Foundations with recess

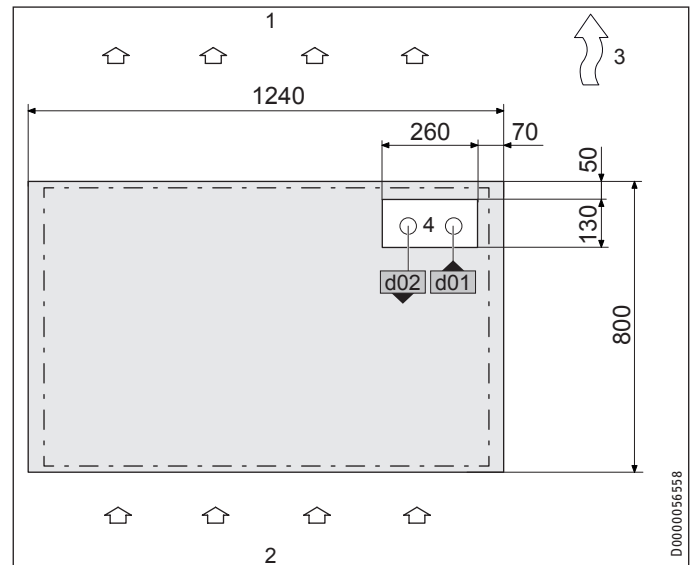

- 1 Air discharge
- 2 Air intake
- 3 Main wind direction
- 4 Recess
- d01 Heat pump flow
- d02 Heat pump return

- ▶ Ensure that the foundations offer an adequate recess.

#### Example: Routing pipes in the base

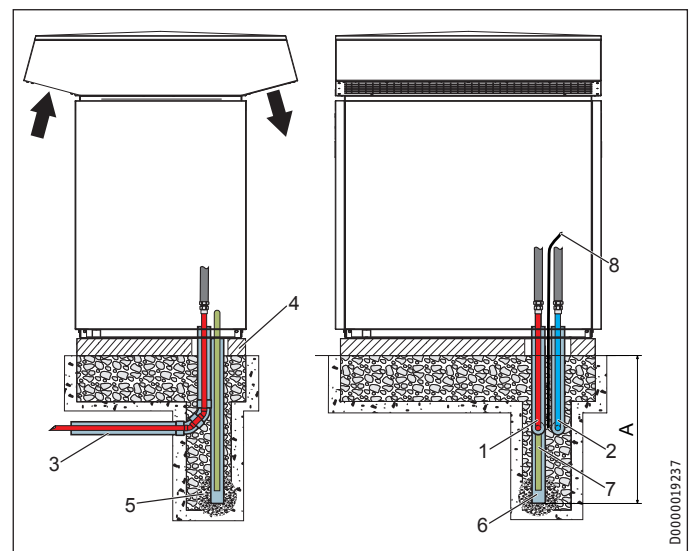

- A Depth of frost line
- 1 Heating circuit flow
- 2 Heating circuit return
- 3 Conduit for supply lines/cables
- 4 Foundation
- 5 Gravel bed
- 6 Drainage pipe
- 7 Condensate drain hose
- 8 Electrical cables/leads

# INSTALLATION

## Preparations

Observe the following information:

- Also protect all supply lines/cables against humidity, damage and UV radiation by means of a conduit.
- Allow the conduits for the supply lines to protrude slightly above the foundations. Ensure that no water can enter the conduits.
- To facilitate connection to the appliance, we recommend using flexible supply pipes/cables in the case of outdoor installation.
- Only use weather-resistant cables.
- Protect the heating circuit flow and return lines against frost with sufficient thermal insulation. Provide thermal insulation in accordance with applicable regulations.



### Note

When routing the condensate drain hose, observe chapter "Installation / Condensate drain".

### 9.3.2 Indoor installation



### Material losses

The installation room floor must be water resistant. During appliance operation, the outdoor air releases up to 50 l of condensate per day. If humidity levels in the installation room are high, condensate may form on the appliance and air hoses. If the condensate drain is not installed correctly or if maintenance is not carried out properly, water may escape. We recommend installing a drain in the installation room floor.

The room where the appliance is installed must meet the following conditions:

- free from the risk of frost
- The room must not be subject to a risk of explosions arising from dust, gases or vapours.
- If installing the appliance in a plant room together with other heating equipment, ensure that the operation of other heating equipment will not be compromised.
- Minimum volume of the installation room. The minimum volume of the installation room is assured if the minimum clearances are observed.
- Load bearing floor (for the weight of the appliance, see chapter "Specification / Data table").
- ▶ For installation on floating screeds, make provisions for quiet heat pump operation.

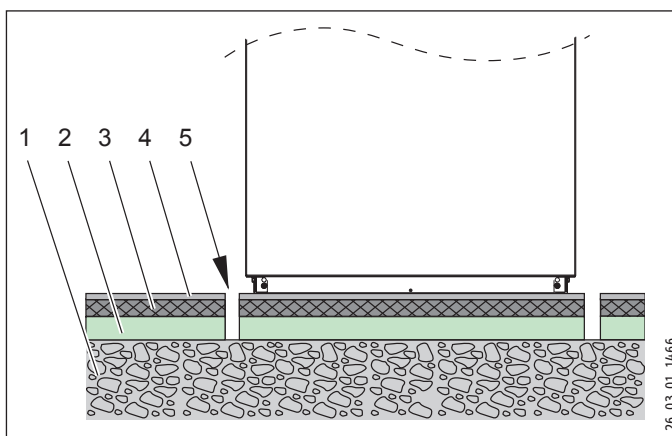

- 1 Concrete base
- 2 Impact sound insulation
- 3 Floating screed
- 4 Floor covering
- 5 Recess

- ▶ Isolate the installation surface around the heat pump by means of a recess. After completing the installation, seal the recess with a water-impervious and sound insulating material, such as silicone for example.

Observe the following information:

- Connect the heating circuit flow and return lines via flexible pressure hoses. Suitable pressure hoses are listed in chapter "Appliance description / Required accessories for indoor installation".



### Note

For details of the dimensions and positions of the air intake and discharge apertures, as well as the outlets for hydraulic lines and power cables, see chapter "Specification / Dimensions and connections / indoor installation".

## 9.4 Electrical installation



### WARNING Electrocutation

Carry out all electrical connection and installation work in accordance with national and regional regulations.



### WARNING Electrocutation

Only use a permanent connection to the power supply. Ensure the appliance can be separated from the power supply by an isolator that disconnects all poles with at least 3 mm contact separation. This requirement can be met with contactors, circuit breakers, fuses/MCBs, etc.



### Note

The specified voltage must match the mains voltage.

- ▶ Observe the type plate.

- ▶ For wiring, use cable with the relevant cross-sections. Observe the applicable national and regional regulations.

MCB/fuse rating	Conductor cross-section
16 A	2.5 mm <sup>2</sup> 1.5 mm <sup>2</sup> for only two live wires and routing on a wall or in an electrical conduit on a wall.

# INSTALLATION

## Installation

The electrical data can be found in the chapter "Specification". The bus requires a J-Y (St) 2x2x0.8 mm<sup>2</sup> cable.

**! Material losses**  
Provide separate fuses/MCBs for the three power circuits, i.e. those of the appliance, the control unit and the electric emergency/booster heater.

**! Material losses**  
Provide common fuses/MCBs for the control cable of the appliance and the heat pump manager.

### 9.5 Buffer cylinder

The installation of a buffer cylinder is essential to ensure trouble-free operation of the appliance.

The buffer cylinder provides hydraulic separation of the volume flows in the heat pump circuit and heating circuit, and also serves as an energy source for defrosting.

**! Material losses**  
A buffer cylinder with diffusion-proof insulation is essential for cooling mode.

## 10. Installation

### 10.1 Transport

- ▶ When transporting the appliance, be aware of its centre of gravity.
- The centre of gravity is in the area where the compressor is located.
- Lifting slings for handling the standard appliance can be hooked in anywhere on the bottom of the frame.
- ▶ Protect the appliance against heavy impact during transport.



- If the appliance needs to be tilted during transport, this must only be for a short time and it must only be tilted on one of its longitudinal sides. When transporting the appliance, ensure the compressor is on the upper appliance side.
- The longer the appliance is tilted, the greater the distribution of refrigerant oil in the system.
- ▶ Wait approximately 30 minutes before starting the appliance after it has been tilted.

### 10.2 Siting and connecting the appliance

- Note**
- Two screws are available at the top of the appliance frame to secure the cover.
  - At the bottom of the frame, one screw is available on each side to secure the side panels.

- ▶ Wind the six screws out of the appliance frame and keep them safe.

#### WPL cool

- ! Material losses**  
With these appliances, the heating circuit flow and return lines must be insulated with vapour diffusion-proof material.

#### 10.2.1 Outdoor installation

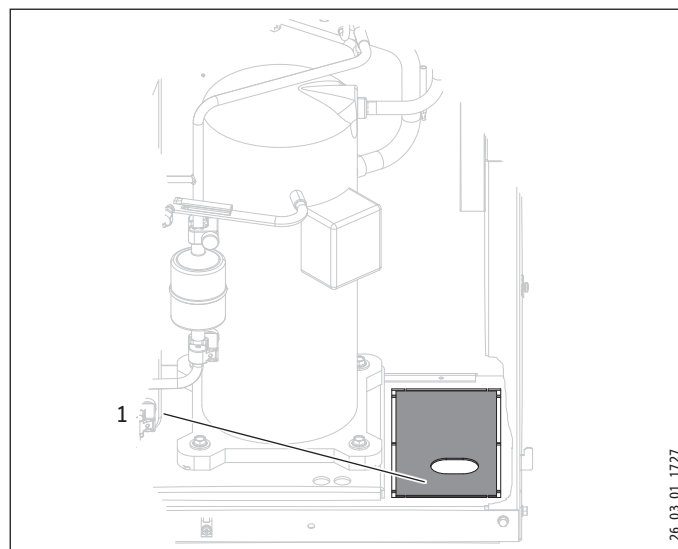

- 1 Knock-out "supply line entry"
- ▶ Remove the knock-out "supply line entry" in the bottom of the appliance.
  - ▶ Position the standard appliance on the prepared substrate.
  - ▶ Observe minimum clearances (see chapter "Preparations / Minimum clearances").



# INSTALLATION

## Installation

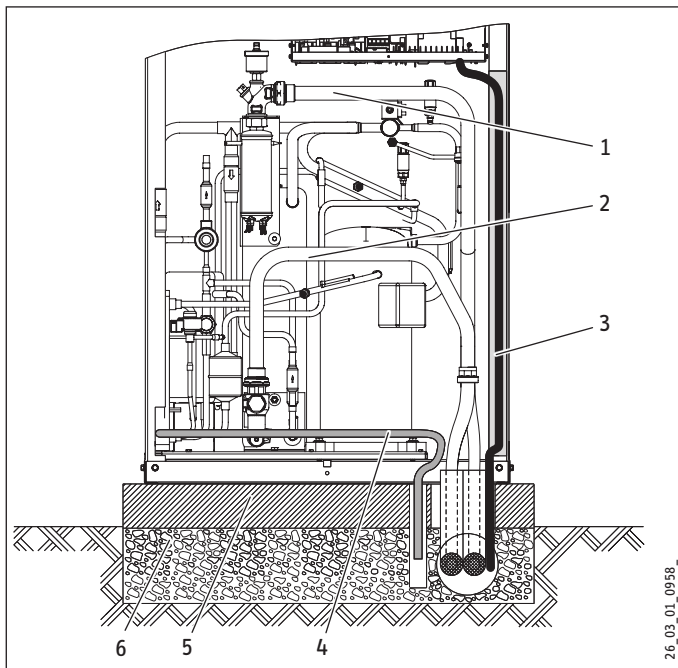

- 1 Pipe bend for heating circuit flow
- 2 Pipe bend for heating circuit return
- 3 Cable duct
- 4 Condensate drain hose
- 5 Concrete foundation
- 6 Coarse gravel back filling

- ▶ Fit the pipe bends "heating circuit flow" and "heating circuit return".
- ▶ Route the supply pipes/cables from below through the knock-out in the bottom and into the appliance.
- ▶ Route the electrical cables in a cable duct.



### Material losses

- Rodents may get into the appliance through the knock-out aperture.
- ▶ Close off the knock-out aperture.

### 10.2.2 Indoor installation

- ▶ Position the standard appliance on the prepared substrate.
- ▶ Pay attention to the air discharge direction.
- ▶ Place the casing cover on the appliance and secure with two screws.

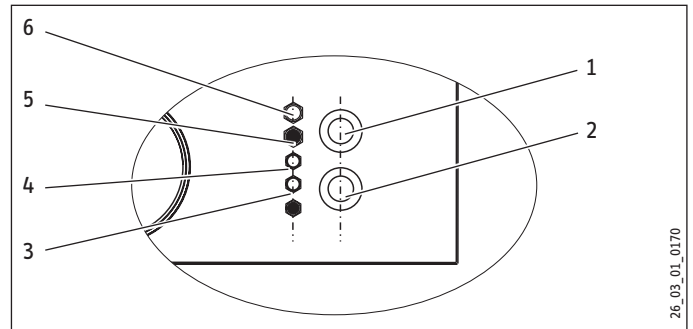

- 1 "Heating flow" connection
- 2 "Heating return" connection
- 3 BUS cable
- 4 Control cable
- 5 Electric emergency/booster heater power cable
- 6 Appliance power cable

- ▶ In the cover, cut out the pipe outlets for the "heating flow" and "heating return" connections.
- ▶ Route the pressure hoses from above through the cover and into the appliance.
- ▶ Route the electrical cables from above through the cable entries and into the appliance.

With the indoor installation, rotate the connector for the "heating flow" connection through approx. 145°.



# INSTALLATION

## Installation

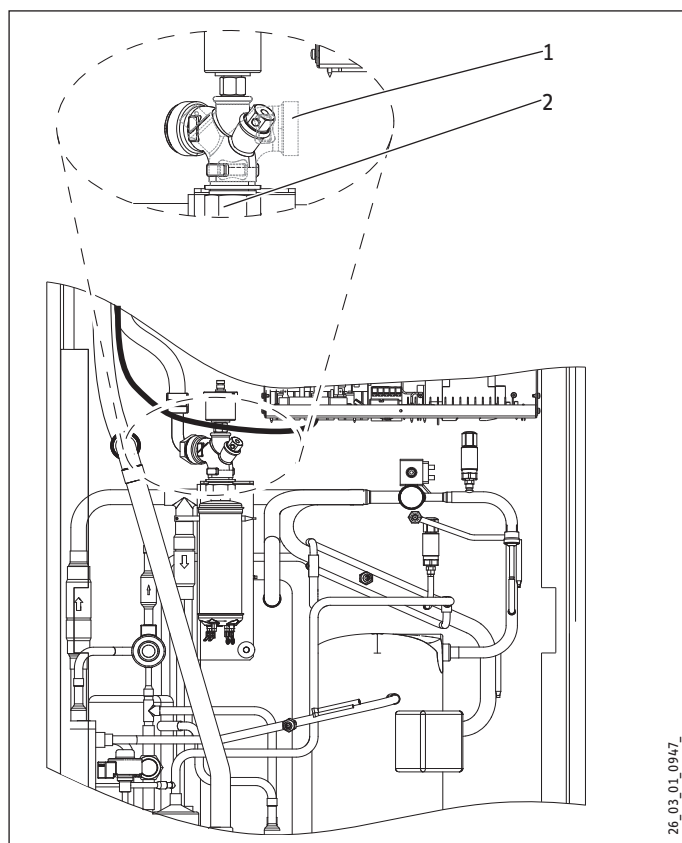

- 1 Connector
- 2 Union nut

- ▶ Loosen the union nut.
- ▶ Rotate the connector.
- ▶ Retighten the union nut.

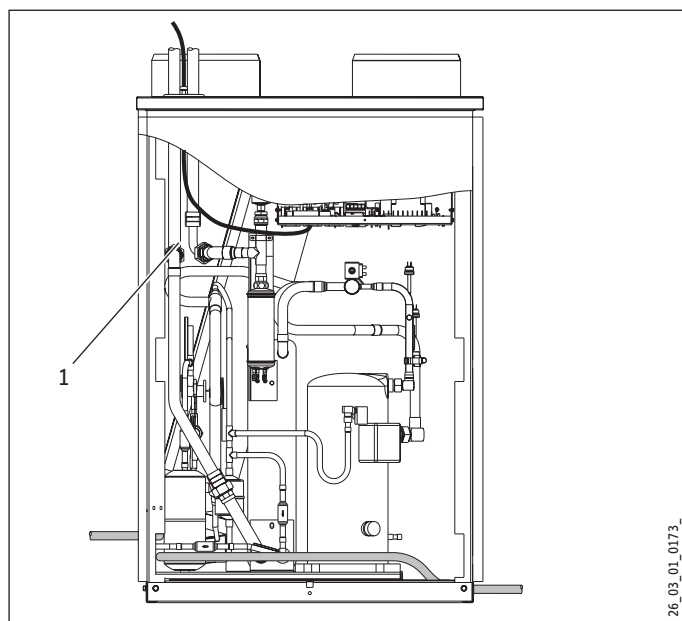

- 1 Pipe bend for heating circuit return
- ▶ Fit the "heating circuit return" pipe bend.

### 10.3 Heating water connection



#### Material losses

The heating system to which the heat pump is connected must be installed by a qualified contractor in accordance with the water installation drawings that are part of the technical guides.

- ▶ Before connecting the heat pump, flush the pipework thoroughly with suitable water. Foreign bodies, such as rust, sand or sealant can impair the operational reliability of the heat pump.
- ▶ Connect the heat pump on the heating water side. Check for tightness.
- ▶ Connect the flexible pressure hoses to the connectors. The pressure hoses must be at least 1 metre long.
- ▶ Ensure that the heating flow and return are connected correctly.
- ▶ Provide thermal insulation in accordance with applicable regulations.
- ▶ When sizing the heating circuit, observe the internal pressure differential (see chapter "Specification / Data table").

Structure-borne noise is largely prevented by the anti-vibration construction of the heat pump and by the flexible pressure hoses, which act as anti-vibration mounts.

#### 10.3.1 Oxygen diffusion



#### Material losses

Avoid open vented heating systems and underfloor heating systems with plastic pipes which are permeable to oxygen.

In underfloor heating systems with plastic pipes that are permeable to oxygen and in open vented heating systems, oxygen diffusion may lead to corrosion on the steel components of the heating system (e.g. on the indirect coil of the DHW cylinder, on buffer cylinders, steel radiators or steel pipes).

- ▶ With heating systems that are permeable to oxygen, separate the heating system between the heating circuit and the buffer cylinder.



#### Material losses

The products of corrosion (e.g. rusty sludge) can settle in the heating system components, which may result in a lower output or fault shutdowns due to reduced cross-sections.

### 10.4 Second heat source

For dual mode systems, always connect the heat pump into the return of the second external heat source, e.g. oil boiler.

# INSTALLATION

## Installation

### 10.5 Filling the heating system

#### Heating water quality

Carry out a fill water analysis before filling the system. This may, for example, be requested by the relevant water supply utility.



#### Material losses

To avoid damage as a result of scaling, it may be necessary to soften or desalinate the fill water. Always observe the fill water limits specified in the "Specification / Data table" chapter.

► Recheck these limits 8-12 weeks after commissioning and as part of the annual system maintenance.



#### Note

With a conductivity > 1000  $\mu\text{S}/\text{cm}$ , desalination treatment is recommended in order to avoid corrosion.



#### Note

Suitable appliances for water softening and desalinating, as well as for filling and flushing heating systems, can be obtained from trade suppliers.



#### Note

If you treat the fill water with inhibitors or additives, the same limits apply as for desalination.

#### 10.5.1 Filling the heating system

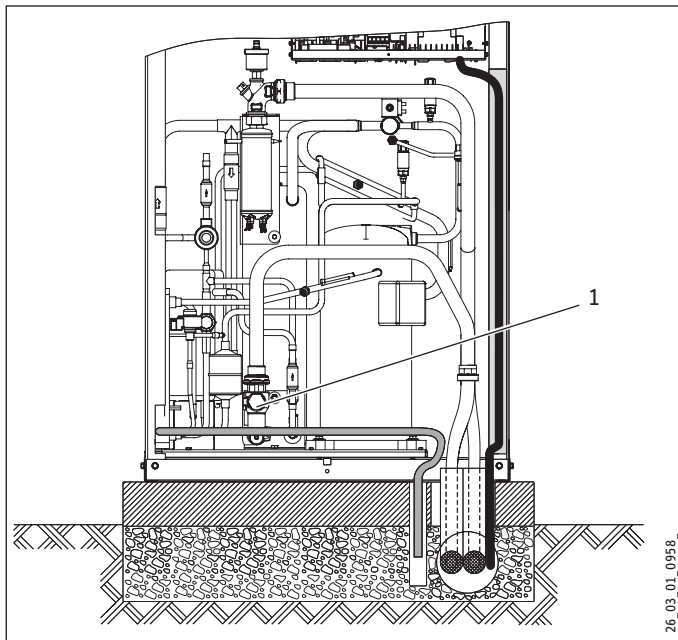

1 Drain

- Fill the heating system via the drain.
- After filling the heating system, check the connections for tightness (visual and physical inspection).

#### 10.5.2 Venting the heating system

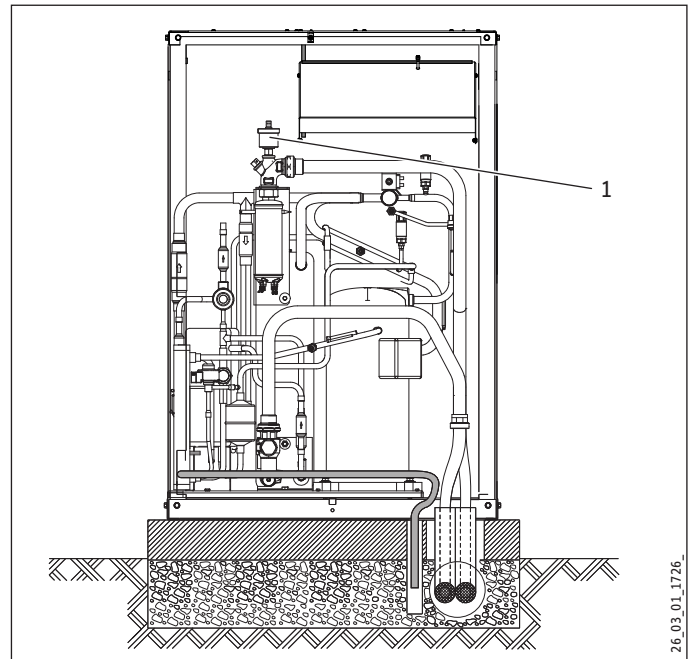

1 Quick-action air vent valve

- Vent the pipework carefully.
- In doing so, also activate the quick-action air vent valve.

### 10.6 Minimum flow rate



#### Note

In combination with a hydraulic module or integral cylinder, the flow rate can be checked and set at the heat pump manager. Observe that the flow rate is set indirectly via the rating of the pump used.

- Call up the flow rate in the heat pump manager menu "INFO / HEATING / FLOW RATE" or "INFO / DHW / FLOW RATE".
- Adjust the flow rate in the heat pump manager menu "COMMISSIONING / HEATING / HEATING CIRC PUMP RATE" or "COMMISSIONING / DHW / DHW PUMP RATE".

The minimum flow rate is set via the temperature differential of the buffer circuit.

Set the buffer charging pump so that the value is equal to or lower than the maximum temperature differential.

The setting is made in heat pump mode. In order to do this,, firstly make the following settings:

- Temporarily remove the fuse from the electric emergency/booster heater to isolate the emergency/booster heater from the power supply. Alternatively, switch OFF the second heat generator.
- Operate the appliance in heating mode.

# INSTALLATION

## Installation

### 10.6.1 Flow rate with buffer cylinder

When using a buffer cylinder, in menu "SETTINGS / HEATING / STANDARD SETTINGS", set parameter "BUFFER OPERATION" to "ON".

The flow rate can be adjusted using the temperature differential of the buffer circuit. The value must not fall below the minimum flow rate.

Maximum temperature differential on the heating side with buffer cylinder:

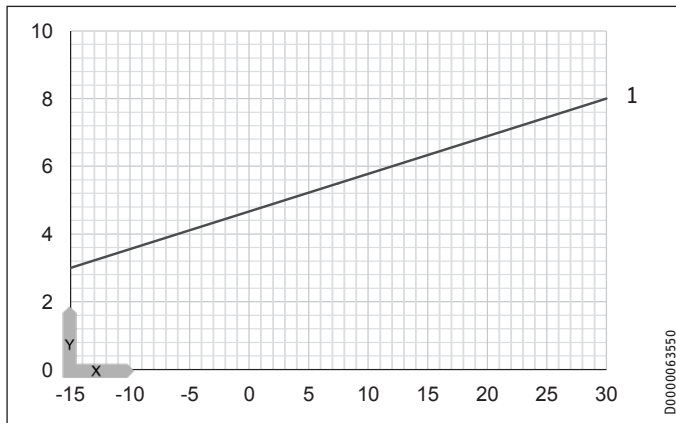

- 1 Nominal flow rate
- X Outside temperature [°C]
- Y Maximum temperature differential [K]

- ▶ Make the settings at the circulation pump when the temperature differential between the flow and return temperature has stabilised.
- ▶ Compare the resulting temperature difference between the flow and return at the appliance with the diagram "Maximum temperature differential on the heating side with buffer cylinder".
- ▶ Set the buffer charging pump so that the maximum temperature differential is achieved or undershot.
- ▶ If the appliance will be used for DHW heating, check the setting of the delivery head in DHW mode.
- ▶ If necessary, adjust the delivery head setting for the DHW primary pump.
- ▶ Set the buffer charging pump and the DHW primary pump to  $\Delta p$  constant.

### 10.7 Condensate drain

A condensate drain hose is fitted to the defrost pan to enable the condensate to drain off. The condensate drain hose is delivered inside the refrigeration unit.

- ▶ Ensure the condensate drain hose is not kinked.
- ▶ Ensure the condensate drain hose is not inserted airtight into a drain. Unhindered drainage requires an ingress of air.
- ▶ Route the hose with a continuous fall.
- ▶ Use a suitable condensate pump if there is insufficient fall. Take the building characteristics into account.
- ▶ If using a condensate pump, ensure that it delivers at least 6 l/min.

#### 10.7.1 Outdoor installation

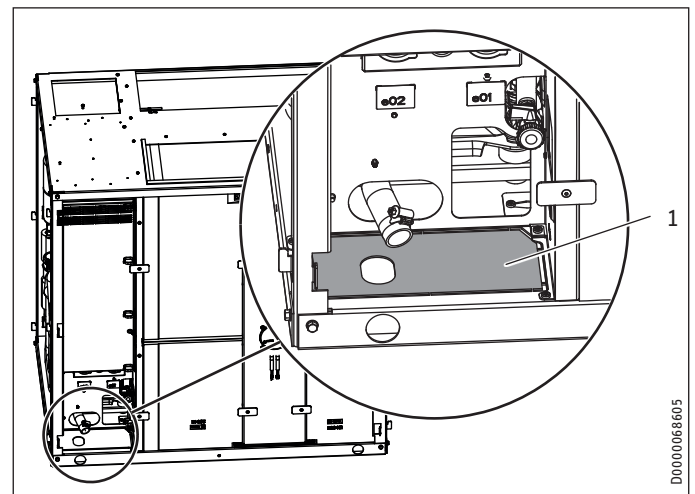

- 1 Knock-out "supply line entry"
- ▶ Route the condensate drain hose downwards through the knock-out "outlet for supply pipe/cable" and out of the appliance.
- ▶ Channel the condensate into a drain or allow it to drain into a coarse gravel soakaway. Ensure the pipework is free from the risk of frost.

#### 10.7.2 Indoor installation

You can route the condensate drain hose out of the appliance towards the left through the knock-out "condensate drain outlet" (see chapter "Specification / Dimensions and connections / Indoor installation") or downwards through the floor plate.

# INSTALLATION

## Power supply

### Condensate drain towards the left

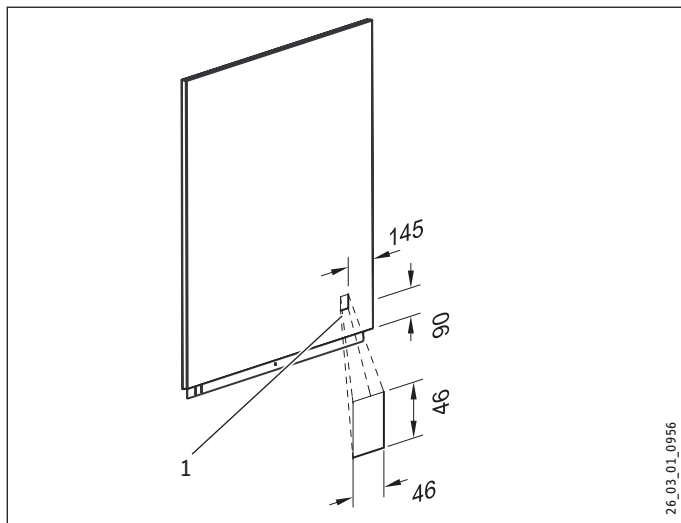

#### 1 Knock-out "condensate drain outlet"

- ▶ Use pliers to remove the knock-out "condensate drain outlet" from the left-hand side panel.
- ▶ Route the condensate drain hose to the left and out of the appliance.
- ▶ Route the condensate into a drain.

### Condensate drain downwards

If a bottom drain is provided, you can drain the condensate downwards through the "supply line entry" in the bottom of the appliance.

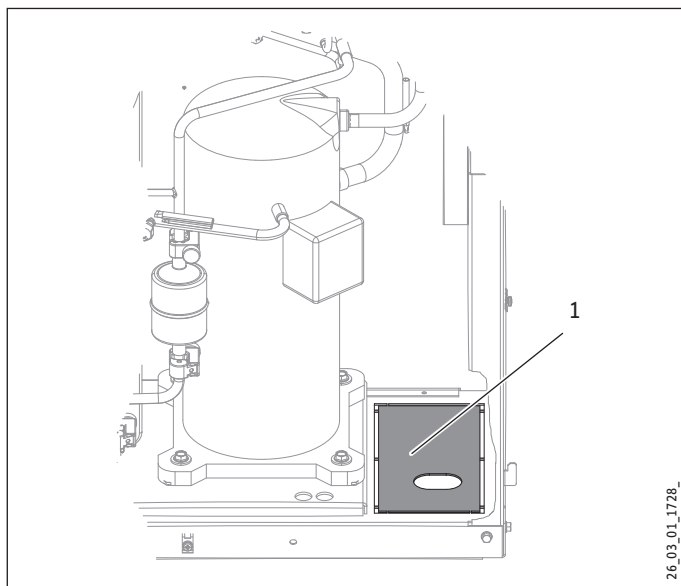

#### 1 Knock-out "supply line entry"

- ▶ Remove the knock-out "supply line entry" in the bottom of the appliance.
- ▶ Route the condensate drain hose diagonally through the knock-out aperture "supply line entry".
- ▶ Secure the condensate drain hose to ensure it does not slip out of place.
- ▶ Route the condensate into the drain in the floor.

### 10.8 Checking the draining of condensate

After routing the condensate drain hose, check that the condensate can drain correctly. Proceed as follows:

- ▶ Pour water onto the evaporator, which will then flow into the defrost pan. Please note the maximum condensate drain capacity of 6 l/min.
- ▶ Check whether the water is draining off through the condensate drain hose.

### 10.9 High limit safety cut-out for underfloor heating systems



#### Material losses

In order to prevent excessively high flow temperatures in the underfloor heating system causing damage in the event of a fault, we always recommend using a high limit safety cut-out to limit the system temperature.

## 11. Power supply



#### Note

Please observe the heat pump manager operating and installation instructions.

The connection must only be carried out by a qualified contractor and in accordance with these instructions.

You must have permission to connect the appliance from the relevant power supply utility.

### 11.1 Control panel



#### WARNING Electrocutation

Before working on the appliance, isolate it from the power supply at the control panel.



#### Note

The terminals are located in the appliance control panel.

# INSTALLATION

## Power supply

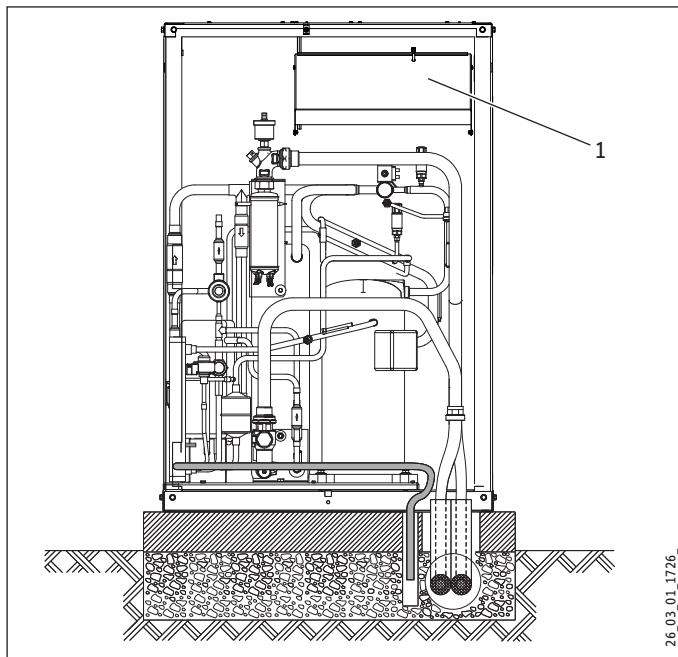

1 Control panel

- ▶ Observe the information in the "Preparations / Electrical installation" chapter.
- ▶ Remove the control panel from the casing.
- ▶ Use appropriate electrical cables in accordance with local regulations.
- ▶ Check that the strain relief fittings are working as intended.
- ▶ Connect the heating circulation pump to the heat pump manager in accordance with the technical guides.

### Terminals X3: Appliance and electric emergency/booster heater (DHC)

- ▶ Connect the appliance to terminal X3.
- ▶ Connect the electric emergency/booster heater to terminal X3 if you want to utilise the following appliance functions:

Appliance function	Effect of the electric emergency/booster heater
Mono energetic operation	If the heat pump undershoots the dual mode point, the electric emergency/booster heater safeguards both the heating operation and the delivery of high DHW temperatures.
Emergency mode	Should the heat pump suffer a fault that prevents its continued operation, the heating output will be covered by the electric emergency/booster heater.
Heat-up program (only for underfloor heating systems)	Where return temperatures are < 25 °C, the electric emergency/booster heater must provide the necessary heat for screed drying. With these low system temperatures, the drying heat must not be provided by the heat pump, otherwise the frost protection of the appliance can no longer be guaranteed during the defrost cycle. When the heat-up program has ended, you can disconnect the electric emergency/booster heater if it is not required for the appliance operation. Please note that during the heat-up program, emergency mode is not available.
Pasteurisation control	The electric emergency/booster heater starts automatically when the pasteurisation control is active in order to regularly heat the DHW to 60 °C to protect it against the growth of legionella bacteria.

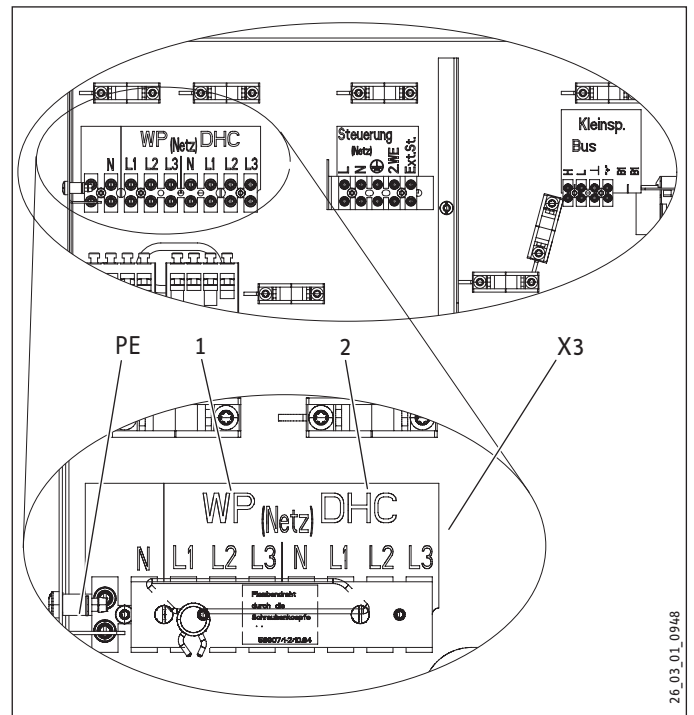

1 Heat pump power supply (WP)  
L1, L2, L3, N, PE

2 Electric emergency/booster heater (DHC)  
L1, L2, L3, N, PE

Connected Load	Terminal assignment			
	L1	L2	L3	PE
2.6 kW	L1			N PE
3.0 kW		L2		N PE
3.2 kW			L3	N PE
5.6 kW	L1	L2		N PE
5.8 kW	L1		L3	N PE
6.2 kW		L2	L3	N PE
8.8 kW	L1	L2	L3	N PE



### Material losses

The compressor in the appliance can only turn in one direction. If the appliance is not connected correctly, the compressor remains in operation for 30 seconds then switches off.

On the heat pump manager display, the fault message NO OUTPUT appears.

- ▶ To change the direction of the rotating field, when the power is disconnected, swap over two phases.
- ▶ Cover and seal the mains terminal (X3) when all electric cables have been connected.

# INSTALLATION

## Fitting casing components

### Connections X4, X2: Control unit and low voltage



#### Note

Provide common fuses/MCBs for the control cable of the appliance and the heat pump manager.

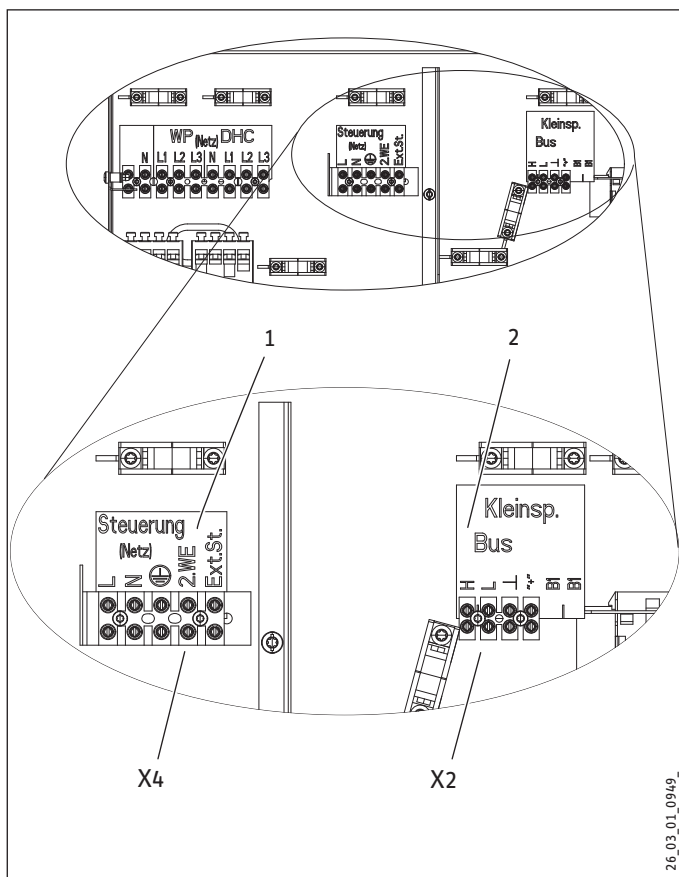

- 1 Control unit ("Steuerung")**  
Power supply: L, N, PE  
  
Control inputs:  
Heat source 2 (2. WE)  
External control, e.g. standalone operation (Ext.St.)
- 2 Low voltage (LV)**  
BUS High H  
BUS Low L  
BUS earth L  
BUS " + " (not required)

## 12. Fitting casing components

### 12.1 Outdoor installation

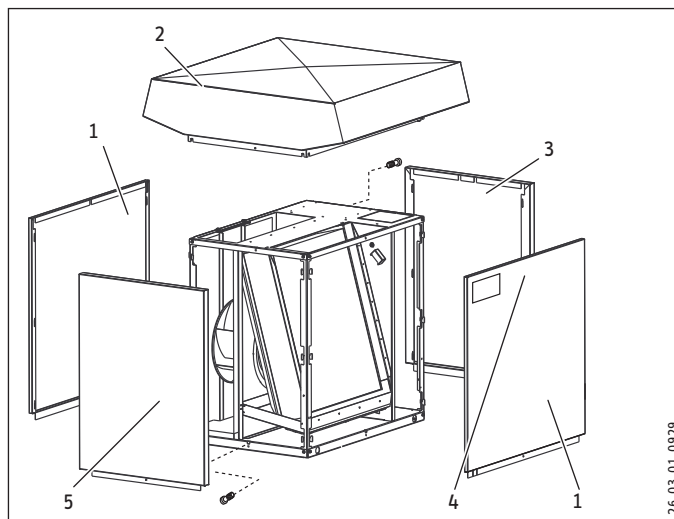

- 1 Side panel
- 2 Cover
- 3 Front panel
- 4 Type plate
- 5 Back panel

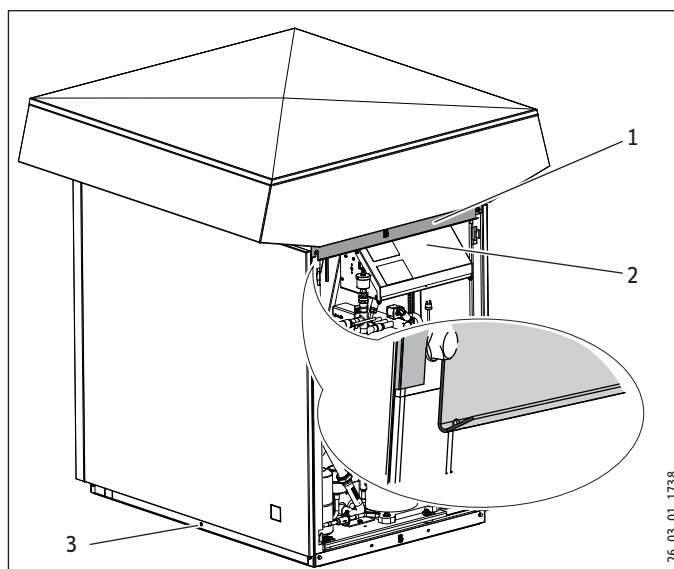

- 1 Bevelled edge
- 2 Control panel
- 3 Screw



#### Material losses

The cover protects the PCB from water ingress.  
► Install the cover with the drip edge above the PCB.

- Secure the cover with two screws.
- Hook the side panels, front panel and back panel into the hooks on the standard appliance. Secure the casing sections at the bottom with one screw each.
- Affix the type plate supplied in a highly visible position on one of the appliance casing panels.



# INSTALLATION

## Fitting casing components

### 12.2 Indoor installation

#### 12.2.1 Sealing the appliance



#### Note

If you want to prevent negative pressure in the installation room, you can seal the appliance by affixing the plastic screen provided.

Before fitting the casing sections, seal the appliance by affixing a plastic film; this will prevent condensation forming under all operating conditions.

The plastic film is supplied with the casing sections.

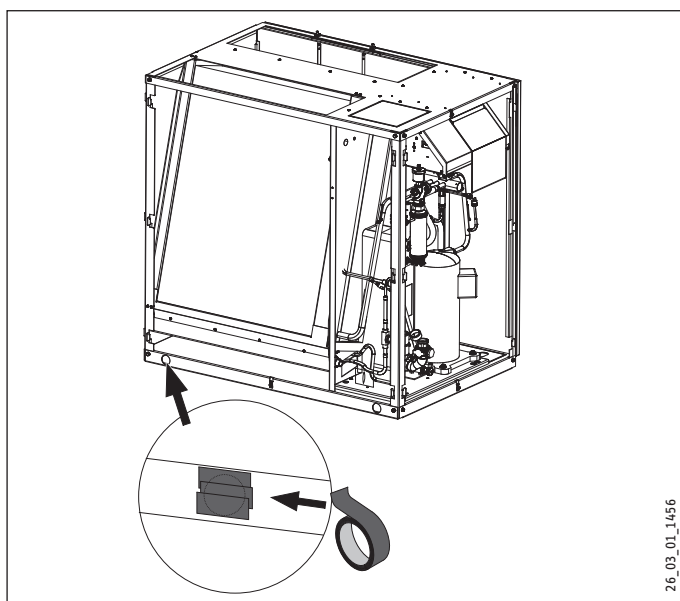

- ▶ Apply fabric tape to seal the hole at the bottom of the frame on the left-hand side. The fabric tape is supplied with the accessory "thermally insulated air hose".

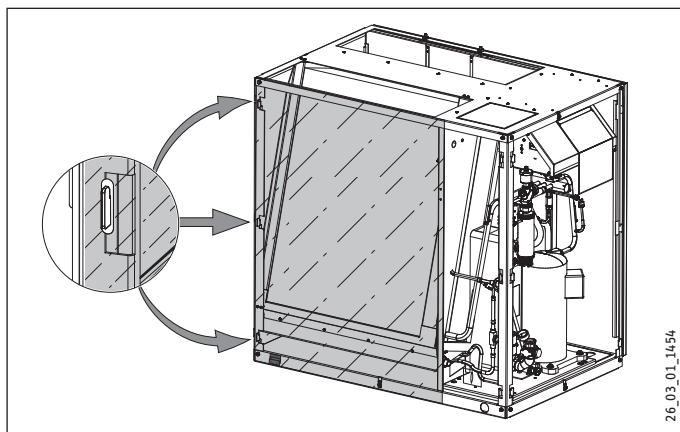

- ▶ Hang the plastic screen with the pre-cut holes onto the hooks on the appliance.

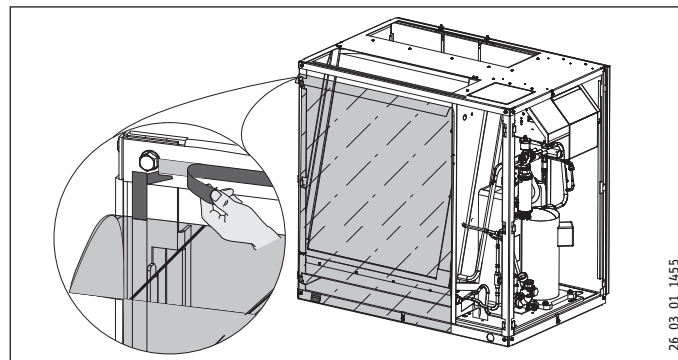

- ▶ Remove the backing from the adhesive strips on the frame and on the plastic screen.
- ▶ Secure the plastic screen by pressing it onto the standard appliance.
- ▶ Seal the gaps around the hooks with fabric tape.

#### 12.2.2 Fitting casing components

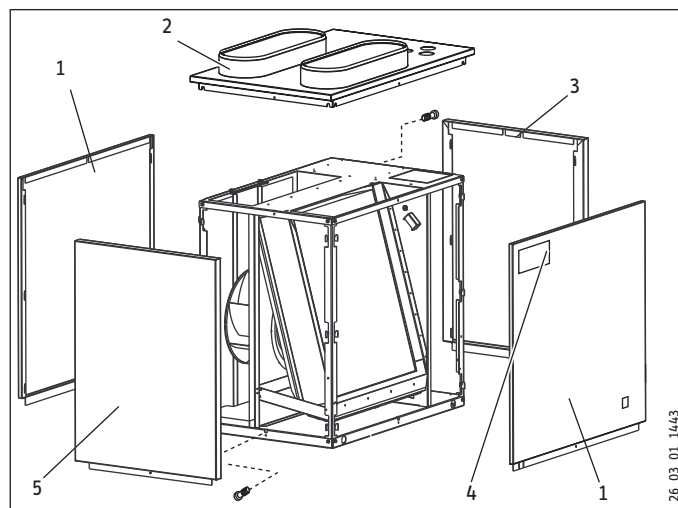

- 1 Side panel
- 2 Cover
- 3 Front panel
- 4 Type plate
- 5 Back panel

- ▶ Place the cover on the appliance and secure with two screws.
- ▶ Hook the side panels, front panel and back panel into the hooks on the standard appliance. Secure the casing components with one screw each.
- ▶ Affix the type plate supplied in a highly visible position on one of the appliance casing panels.

# INSTALLATION

## Fitting casing components

### 12.2.3 Routing air hoses



#### Note

In the case of heat pumps installed indoors, if a blower door test to EN 13829 is to be carried out, then all apertures which are purposely provided in the building envelope must be closed or sealed off before the air hoses are installed.

- ▶ For the blower door test, seal off the heat pump supply air and extract air ducts.



#### Note

Air hoses guide the intake air to the appliance and route the discharge air from the appliance outdoors. They are highly flexible, thermally insulated and self-extinguishing in case of fire.

#### General information

The air hose can be extended by turning the hose spirals into each other. There must be an overlap of approx. 30 cm. The total length of hoses on the air intake and discharge sides must not exceed 8 m.

- ▶ Never incorporate more than four 90° bends. The radius of the bends must be at least 600 mm, relative to the centre of the hose.
- ▶ Cut to size using a sharp knife. The hose spirals can be cut with wire cutters.
- ▶ Secure the air hose at intervals of approx. every 1 m to prevent it from sagging.
- ▶ Manipulate the ends of the air hoses to fit the oval shape of the connectors on the cover and the hose connection panels or wall outlets.

#### Fitting the air hoses

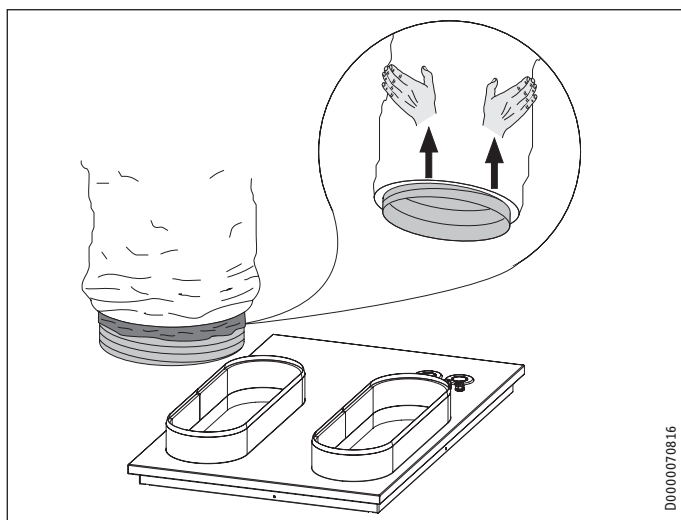

D0000070816

- ▶ Firstly, push the outer hose slightly upwards.

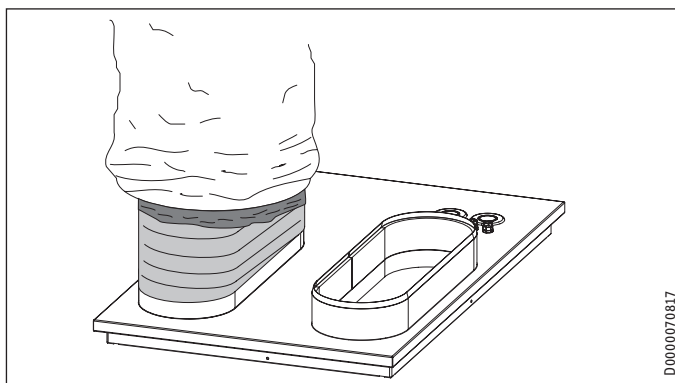

D0000070817

- ▶ Push the inner hose halfway down the connector.

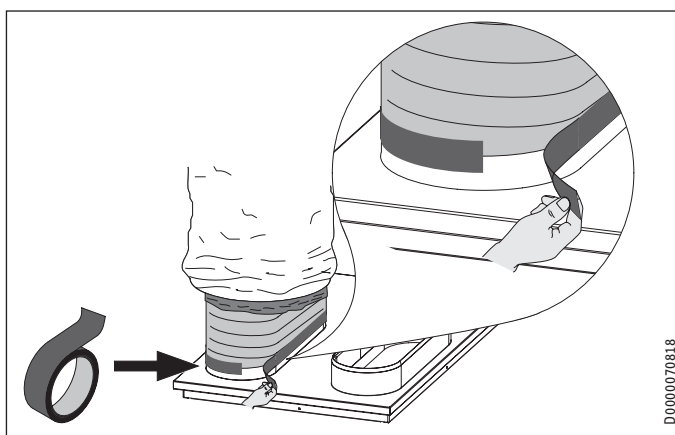

D0000070818

- ▶ Seal the inner hose by affixing it to the connector using the fabric tape provided.

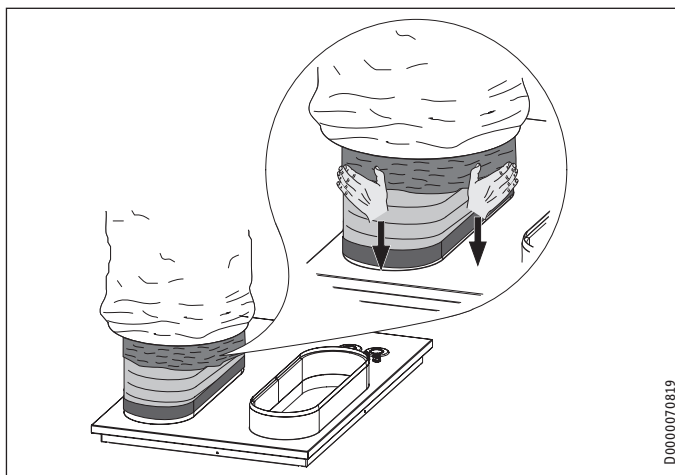

D0000070819

- ▶ With the sound-optimized hoses (LSWP 560-4 S), pull the sheet over the connector.



# INSTALLATION

## Commissioning

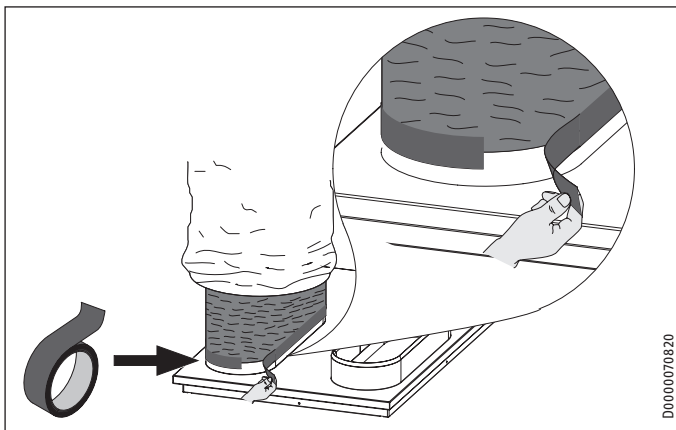

- ▶ With the sound-optimised hoses (LSWP 560-4 S), seal the sheet to the connector using the fabric tape provided.

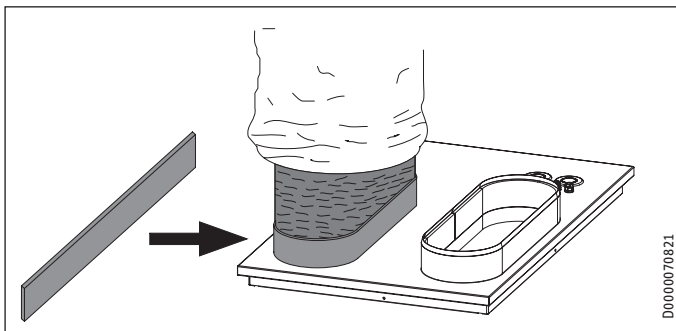

- ▶ Place the sealing strip provided around the connector.

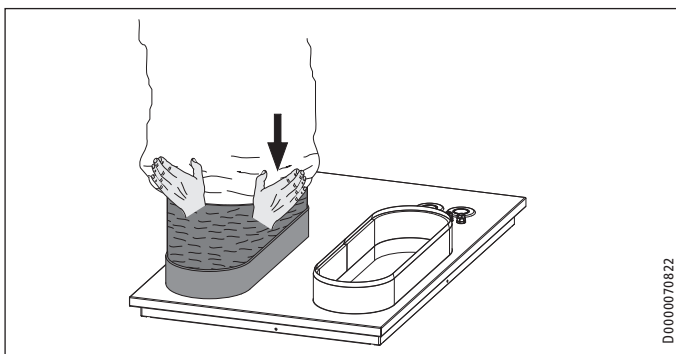

- ▶ Pull the outer hose over the connector.

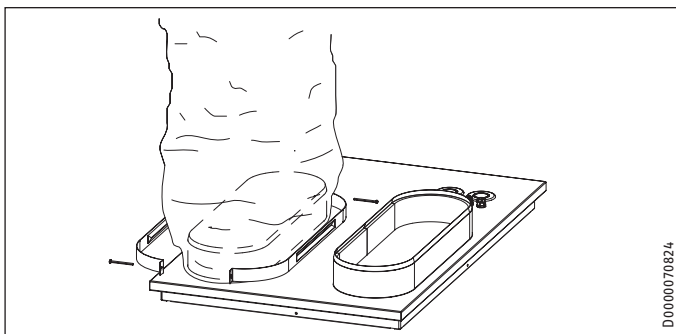

- ▶ Secure the hose using the oval hose clip provided and seal it.

### Insulating the brickwork

Ensure that no cold bridges form between the brickwork and the hose connection panels or wall outlets. Cold bridges can result in condensation forming in the brickwork.

- ▶ If necessary, fit suitable insulation between the brickwork and the hose connection panels or wall outlets.

## 13. Commissioning



### Note

When quick start is used, the starting resistors are not patched in.

- ▶ Do not use quick start when measuring the starting current.

A WPM heat pump manager is required to operate the appliance. All necessary adjustments prior to and during operation are made on this device.

A contractor must commission the appliance, make all the settings at the commissioning level of the heat pump manager, and instruct the user.

Carry out commissioning in accordance with these installation instructions and the operating and installation instructions of the heat pump manager. Our customer support can assist with commissioning, which is a chargeable service.

Where this appliance is intended for commercial use, the regulations of the relevant Health & Safety at Work Act may apply during commissioning. For further details, check with your local authorising body; in Germany for example, this is the TÜV.

### 13.1 Check before commissioning the heat pump manager



### Material losses

Observe the maximum system temperature for underfloor heating systems.

- ▶ Check whether the heating system is charged to the correct pressure and whether the quick-action air vent valve in the heat pump is open.
- ▶ Check whether the outside temperature sensor and the return sensor are correctly placed and connected.
- ▶ Check whether additional sensors are correctly positioned and connected.
- ▶ Check whether the power supply is connected correctly.

# INSTALLATION

## Commissioning

### 13.1.1 High limit safety cut-out

At ambient temperatures below  $-15\text{ }^{\circ}\text{C}$  it is possible that the high limit safety cut-out of the electric emergency/booster heater may trip.

- ▶ Check whether the high limit safety cut-out has tripped.
- ▶ Remove the cause of the fault if necessary.

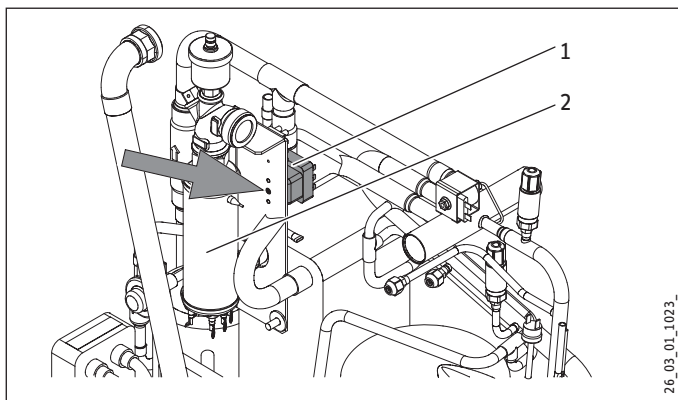

- 1 High limit safety cut-out reset button
- 2 Electric emergency/booster heater

- ▶ Reset the high limit safety cut-out by pressing the reset button.

### 13.2 Commissioning the heat pump manager

Commission the heat pump manager and make all settings in accordance with the operating and installation instructions for the heat pump manager.

### 13.3 Initial start-up

#### 13.3.1 DIP switch (WP-Typ)

- ▶ Open the control panel.
- ▶ The IWS is located on the r.h. side.

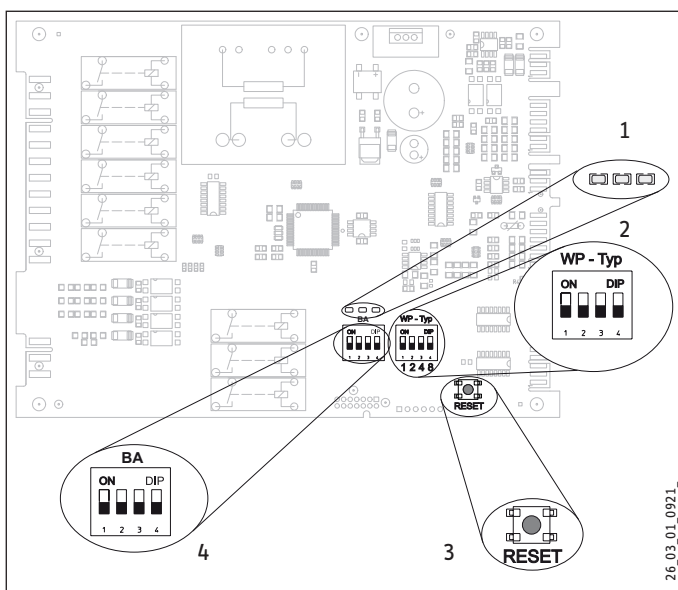

- 1 LEDs
- 2 DIP switch (WP-Typ)
- 3 Reset button
- 4 DIP switch (BA)

With the DIP switch ("WP-Typ"), you can select the various heat pump types on the IWS.

#### Factory setting:

#### Compressor mode with electric emergency/booster heater

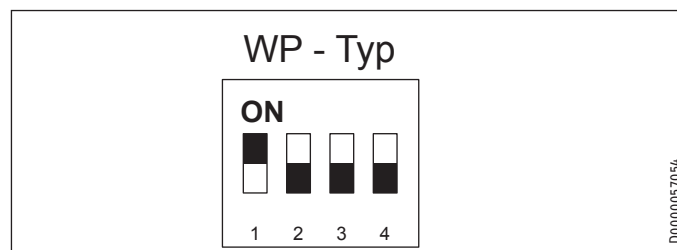

- ▶ Check whether the DIP switch is set correctly.

#### Compressor mode with external second heat generator



#### Material losses

The electric emergency/booster heater must not be connected if a second heat generator is also used.

If the appliance is operated in dual mode operation with an external second heat generator or as module with another identical heat pump, set the DIP switches as follows:

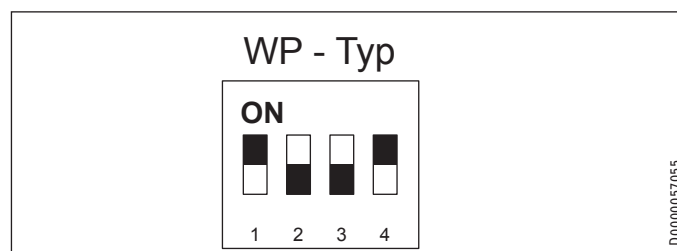

- ▶ Check whether the DIP switch is set correctly.

#### DIP switch (BA)

The heat pump operating mode is set using the DIP switch (BA).

- ▶ Check whether the DIP switch is set correctly.



#### Material losses

DIP switches 3 and 4 must always be set to the OFF position. The heat pump can only be operated when the switches are in this position.

#### WPL E

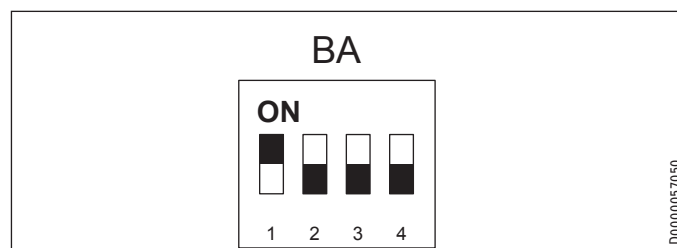

### WPL cool



## 13.4 Settings

### 13.4.1 Heating curve adjustment

The efficiency of a heat pump decreases as the flow temperature rises. Adjust the heating curve carefully. Heating curves that are set too high cause the zone valves or thermostatic valves to close, which may lead to the minimum flow rate required for the heating circuit not being achieved.

► Observe the WPM operating and installation instructions.

The following steps will help you to adjust the heating curve correctly:

- Fully open thermostatic or zone valves in a lead room (e.g. living room and bathroom).  
We do not recommend installing thermostatic or zone valves in the lead room. Control the temperature for these rooms via remote control.
- At different outside temperatures (e.g. -10 °C and +10 °C), adjust the heating curve so that the required temperature is set in the lead room.

Standard values to begin with:

Parameter	Underfloor heating system	Radiator heating system
Heating curve	0.4	0.8
Control response time	5	15
Comfort temperature	20 °C	20 °C

If the room temperature is not high enough in spring and autumn (approx. 10 °C outside temperature), raise the "COMFORT TEMPERATURE" parameter in the heat pump manager menu under "SETTINGS / HEATING / HEATING CIRCUIT".



#### Note

If no remote control is installed, raising the "COMFORT TEMPERATURE" parameter will lead to a parallel offset of the heating curve.

If the room temperature is too low when outside temperatures are also low, increase the "HEATING CURVE" parameter.

If the parameter "HEATING CURVE" has been raised, in the case of high outside temperatures, adjust the zone valve or thermostatic valve in the lead room to the required temperature.



#### Note

Never reduce the temperature in the entire building by closing all zone valves or thermostatic valves, but instead do this by using the setback programs.

When everything has been implemented correctly, the system can be heated to its maximum operating temperature and vented once again.



#### Material losses

For underfloor heating systems, observe the maximum permissible system temperature.

### 13.4.2 Other settings

► For operation with and without a buffer cylinder, see chapter "Operation / Menu structure / Menu SETTINGS / STANDARD SETTING / BUFFER OPERATION" in the WPM operating and installation instructions.

### Using the heat-up program

If you use the heat-up program, make the following settings on the WPM:

- Initially set the parameter "DUAL MODE TEMP HZG" to 30 °C.
- Set the "LOWER APP LIMIT HZG" parameter to 30 °C.



#### Note

Following the heat-up process, return the "DUAL MODE TEMP HZG" and "LOWER APP LIMIT HZG" parameters to their default values or to the system values.

## 14. Appliance shutdown



#### Material losses

Never interrupt the heat pump power supply, even outside of the heating season. Otherwise, system frost protection is not guaranteed.  
The heat pump manager automatically switches the heat pump to summer or winter mode.

### 14.1 Standby mode

To take the appliance out of use, simply set the heat pump manager to "Standby mode". This way, the safety functions that protect the system remain enabled, e.g. frost protection.

### 14.2 Power interruption

If the system is to be isolated from the power supply permanently, please observe the following:



#### Material losses

If the heat pump is completely switched off and there is a risk of frost, drain the system on the water side.

### 15. Appliance handover

Explain the appliance function to users and familiarise them with its operation.



#### Note

Hand over these operating and installation instructions to users for safekeeping.

All information in these instructions must be closely observed. The instructions provide information on safety, operation, installation and maintenance of the appliance.

### 16. Troubleshooting



#### Note

Please observe the heat pump manager operating and installation instructions.



#### Note

The following inspection instructions may only be carried out by a qualified contractor.

If you cannot locate the fault using the heat pump manager, use the controls on the IWS.

- ▶ Open the control panel.
- ▶ Read the following sections on troubleshooting and follow the instructions.

#### 16.1 Controls on the IWS

The IWS helps you to troubleshoot if the fault cannot be identified using the WPM.

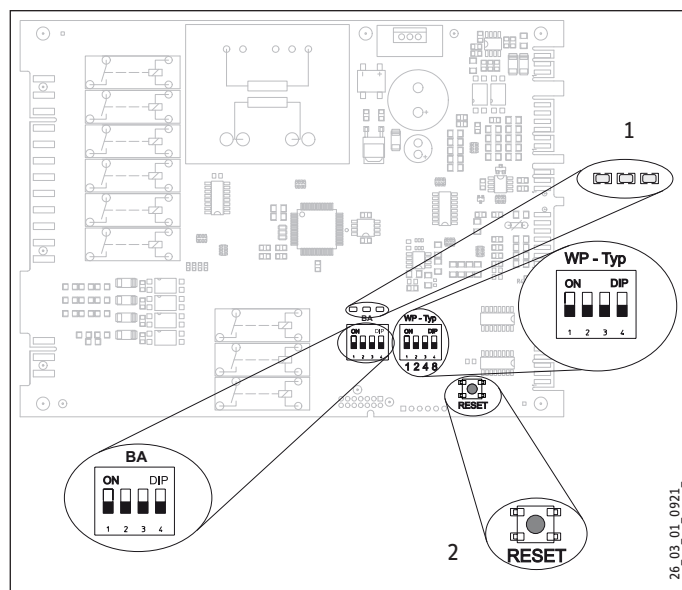

- 1 LEDs
- 2 Reset button

#### Red LED (left)

Faults indicated by the LED:

- High pressure fault
- Low pressure fault
- Central fault
- Hardware fault on the IWS (see fault list, operating and installation instructions for the heat pump manager)

Fault	Cause	Remedy
The appliance stops and restarts after the idle period has expired. The red LED flashes.	There is a heat pump fault.	Check the fault message on the WPM. Find the solution in the WPM instructions (fault list). Reset the IWS.
The appliance shuts down permanently. The red LED is constantly illuminated.	Five faults have occurred within two hours of compressor runtime.	Check the fault message on the WPM. Find the solution in the WPM instructions (fault list). Reset the IWS.

#### Green LED (centre)

The LED flashes during initialisation, and illuminates constantly after the bus address has been assigned successfully. Connection to the WPM has been established.

#### Green LED (right)

No function.

##### 16.1.1 Reset button

If the IWS was not initialised successfully, you can reset it with this reset button. Observe chapter "Reinitialising IWS" in the heat pump manager operating and installation instructions.

##### 16.2 Resetting the high limit safety cut-out

If the heating water temperature exceeds 85 °C, the electric emergency/booster heater shuts down.

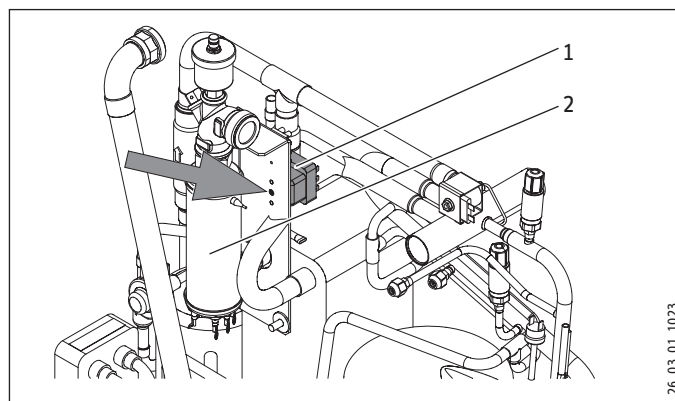

- 1 High limit safety cut-out reset button
- 2 Electric emergency/booster heater

- ▶ Remove the cause of the fault.
- ▶ Reset the high limit safety cut-out by pressing the reset button. If necessary, use a pointed object to do this.
- ▶ Check whether the heating water is being circulated at a sufficiently high flow rate.

### 16.3 Fan noise

The heat pump draws heat from the outdoor air. This causes the outdoor air to cool down. At outside temperatures of 0 °C to 8 °C, the air may be cooled to below freezing point. If under these conditions precipitation occurs in the form of rain or fog, ice may form on the air grille, the fan blades or the airways. If the fan comes into contact with this ice, this creates noise.

#### How to remedy rhythmic scratching or grinding noises:

- ▶ Check whether the condensate drain is clear of obstructions.
- ▶ Carry out a manual defrost, as many times as necessary, until the fan runs freely again. Observe the information in the WPM operating and installation instructions and parameter "START DEFROST" in menu "COMMISSIONING / COMPRESSOR".
- ▶ At outside temperatures above +1 °C, shut down the appliance or switch it over to emergency mode for approx. 1 hour. After this, the ice should have melted.
- ▶ Check that the appliance is installed in line with installation conditions.
- ▶ If the noises occur frequently, notify customer support.

## 17. Maintenance

If heat meters are installed, their sieves should be cleaned regularly.

Regularly remove all leaves and accumulated dirt from the evaporator fins, which can be accessed by removing the side panel on the condenser side.

Check the condensate drain is working correctly. Remove any contamination (see chapter "Clean condensate pan and drain").

We recommend a regular inspection (to establish the current condition of the system), and maintenance if required (to return the system to its original condition).

### 17.1 Clean condensate pan and drain



**WARNING Electrocutation**  
Before removing the casing parts disconnect all polls of the appliance from the power supply.

Environmental influences can lead to the condensate pan and drain becoming contaminated or blocked. To clean, proceed as follows:

- ▶ Remove the casing parts (see chapter "Fitting the casing parts").

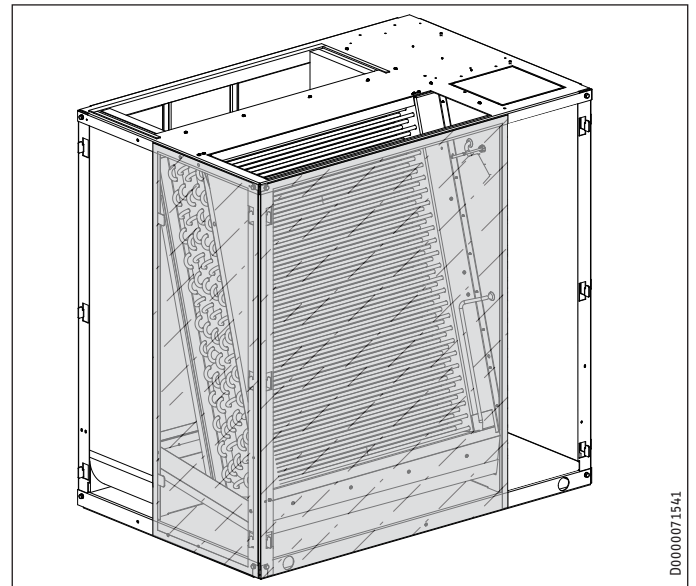

- ▶ When installed indoors, also carefully remove the foil from the appliance frame.

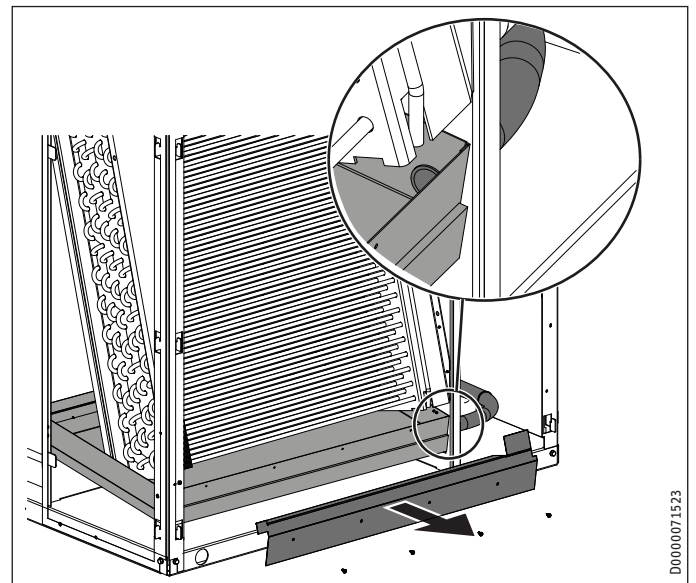

- ▶ Remove the lower cover panel.
- ▶ Clean out the rear section of the condensate pan.
- ▶ Clean out the front section of the condensate pan.
- ▶ Check the hose and the condensate drain pipe, and remove all contaminants and blockages.
- ▶ When installed indoors, carefully re-affix the foil to the appliance frame.
- ▶ Refit the casing parts on the appliance (see chapter "Fitting the casing parts").

## 18. Specification

### 18.1 Dimensions and connections

#### 18.1.1 Outdoor installation

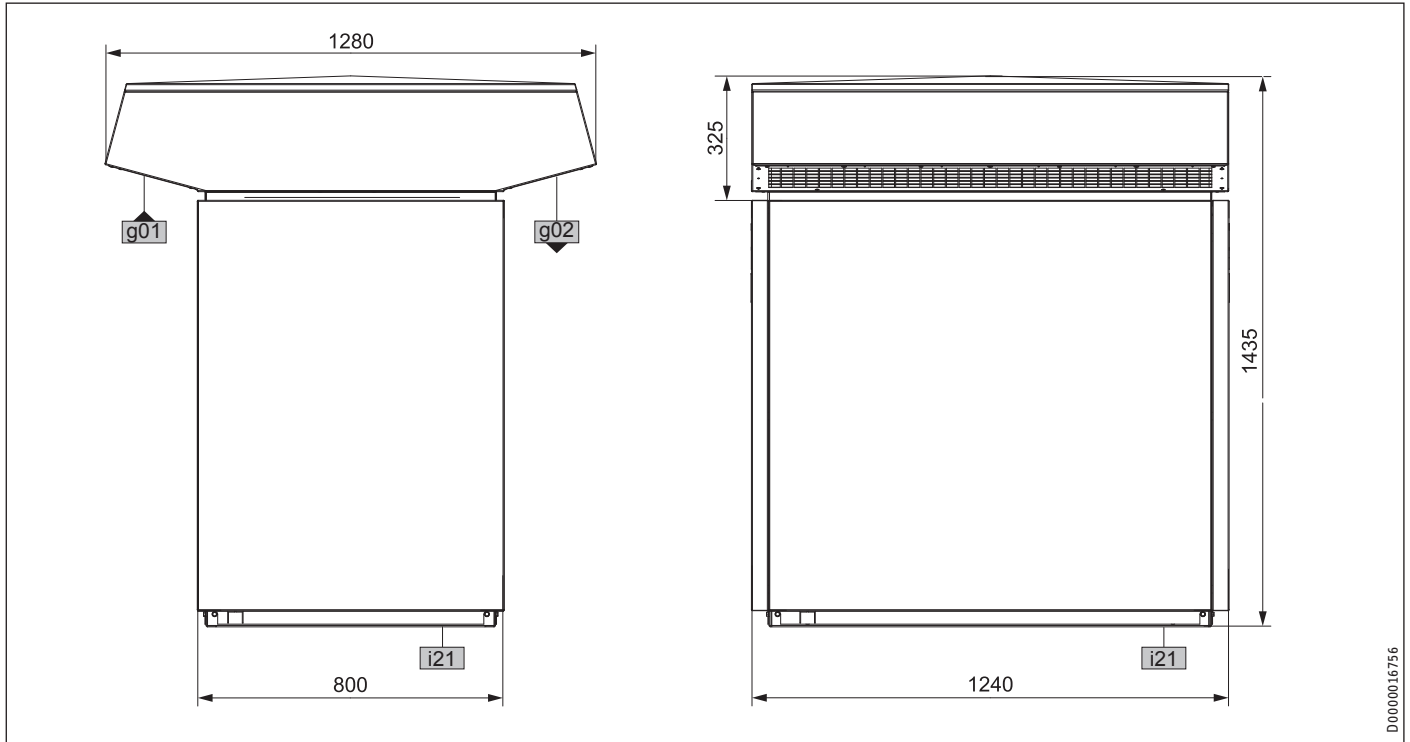

D0000016756

g01	Air intake
g02	Air discharge
i21	Entry supply line

# INSTALLATION Specification

## 18.1.2 Indoor installation

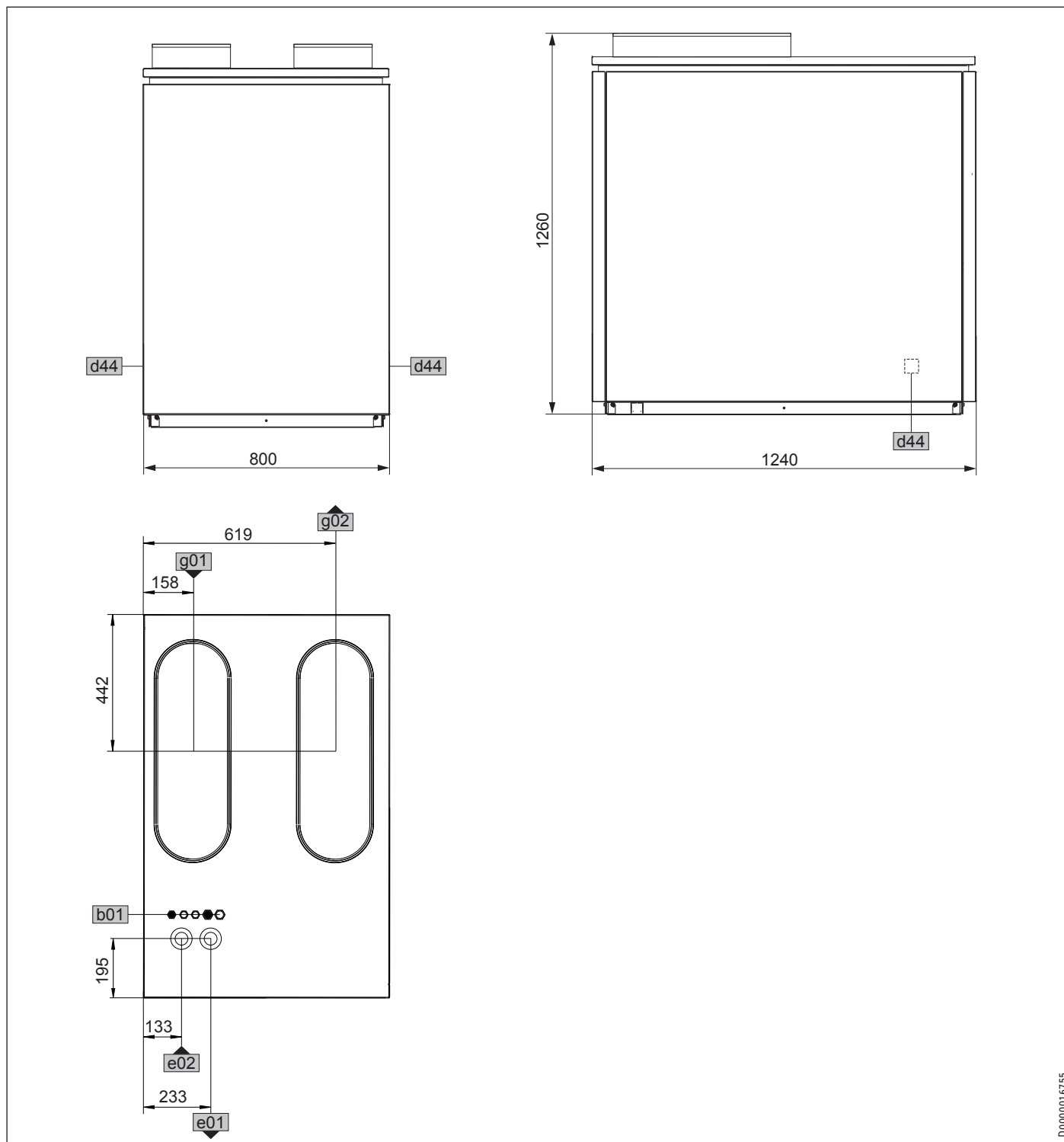

D0000016755

b01	Cable entry		
d44	Condensate drain outlet		
e01	Heating flow	Male thread	G 1 1/4 A
e02	Heating return	Male thread	G 1 1/4 A
g01	Air intake		
g02	Air discharge		

## 18.2 Wiring diagram

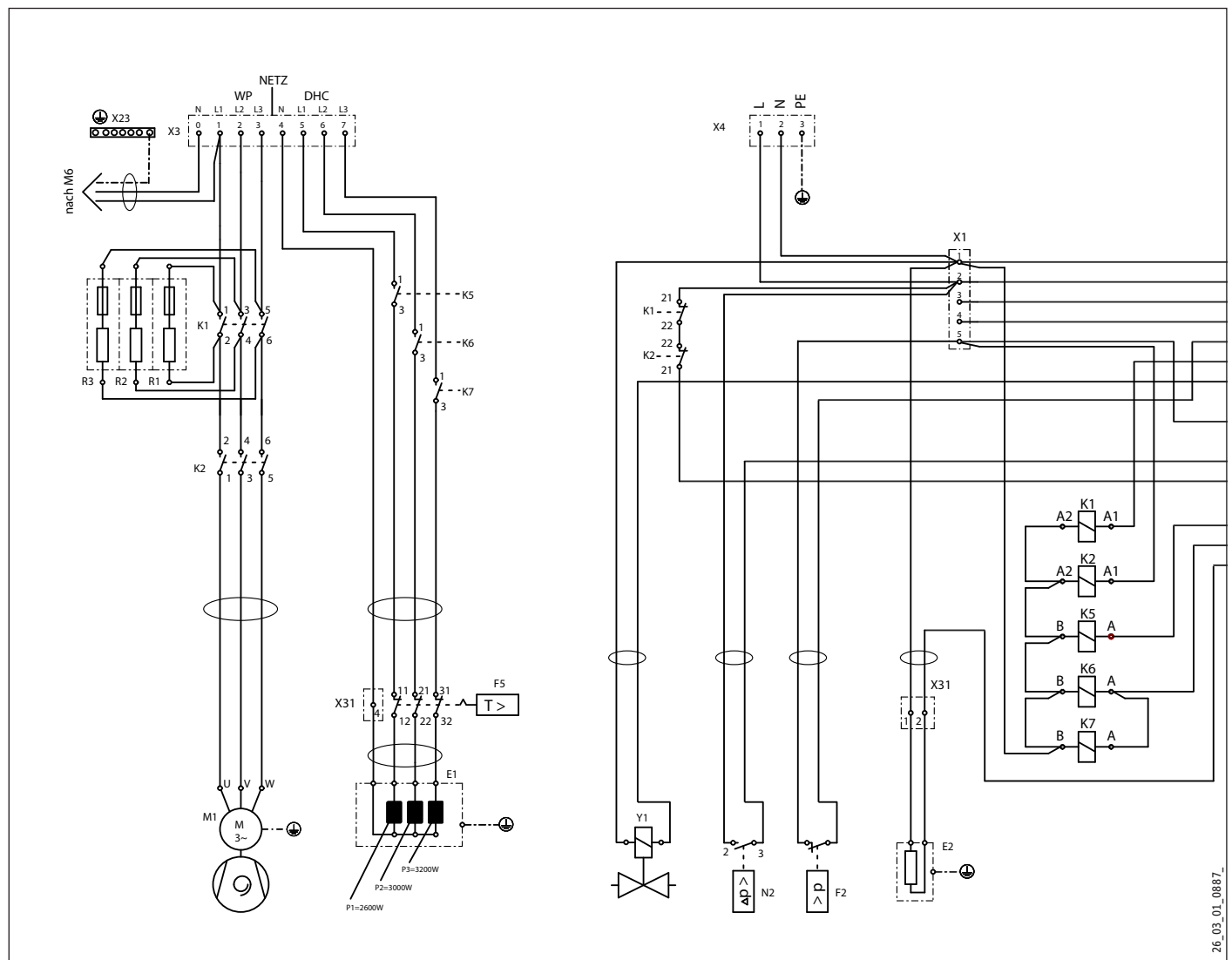

- A2 Integral heat pump control unit IWS
- B1 Temperature sensor, heat pump flow
- B2 Temperature sensor, heat pump return
- B5 Temperature sensor, hot gas
- B6 Temperature sensor, intake air
- B7 Temperature sensor, compressor inlet
- B8 Temperature sensor, evaporator outlet
- B9 Temperature sensor, frost protection
- B10 Temperature sensor, injection
- E1 Electric emergency/booster heater (DHC)
- E2 Oil sump heater
- F2 High pressure switch
- F5 High limit safety cut-out DHC
- K1 Contactor - resistance start
- K2 Compressor start contactor
- K5 DHC relay
- K6 DHC relay
- K7 DHC relay
- M1 Compressor motor
- M6 Fan motor
- M7 Electronic expansion valve stepper motor
- M8 Electronic injection valve stepper motor
- N2 Defrost differential pressure switch

- P1 High pressure sensor
- P3 Low pressure sensor
- R1 Compressor start-up resistor
- R2 Compressor start-up resistor
- R3 Compressor start-up resistor
- X1 Terminals
- X2 Low voltage terminal strip
- X3 Mains terminal
- X4 Control terminal
- X23 Earth block, power supply
- X29 12-pin IWS plug - control unit
- X30 3-pin IWS plug - BUS
- X31 Terminal DHC
- X33 5-pin IWS plug - electronic expansion valve
- X34 7-pin IWS plug - sensors
- X35 6-pin IWS plug - temperature sensors
- X36 3-pin IWS plug - fan
- X37 5-pin IWS plug - electronic injection valve
- X38 3-pin IWS plug - DHC
- X39 Pressure sensor terminal
- X40 Ground temperature sensor terminal
- Y1 Diverter valve, defrost



# INSTALLATION Specification

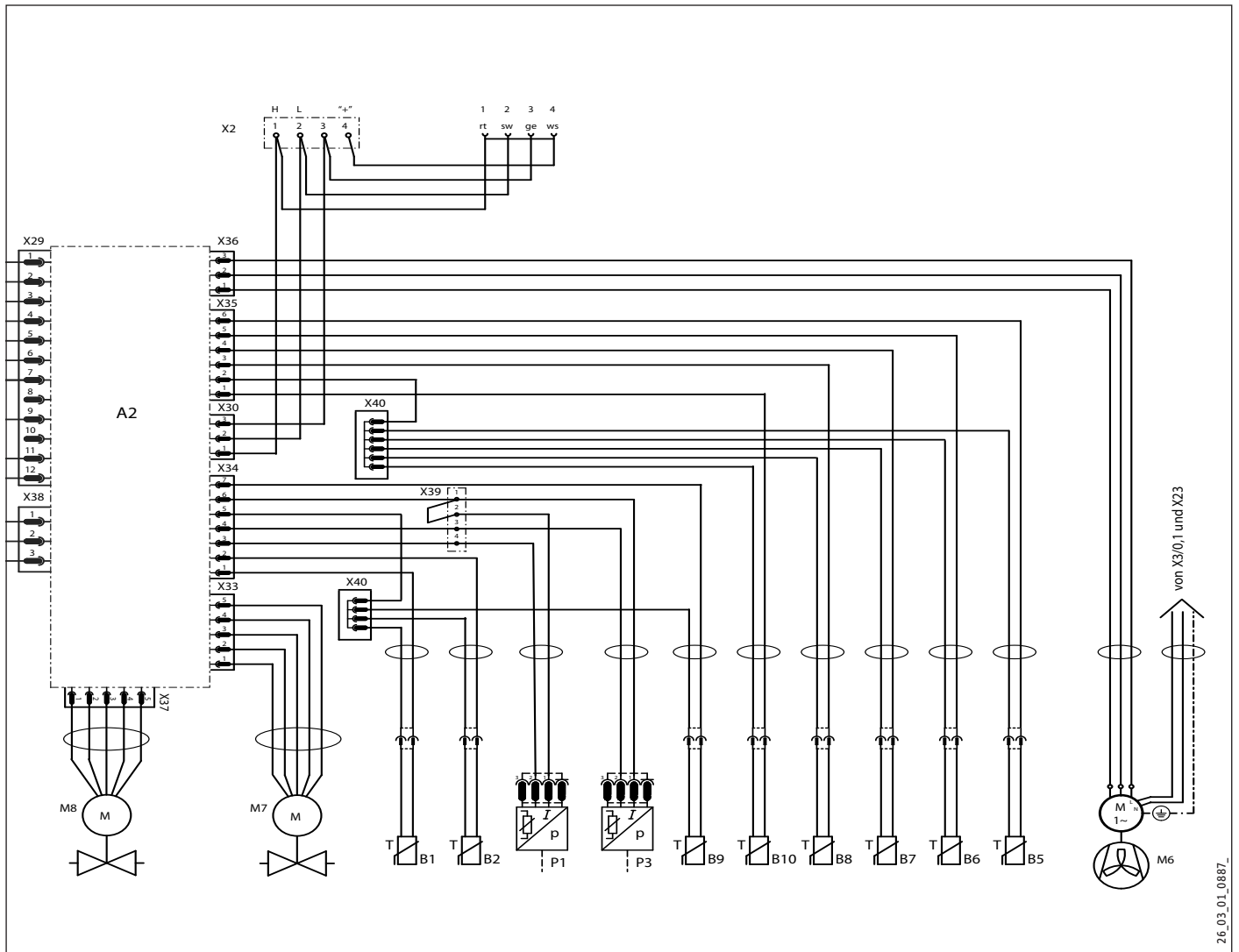

26.03.01\_0887\_

## 18.3 Output diagrams

Heating output diagram WPL 13 E | WPL 13 cool

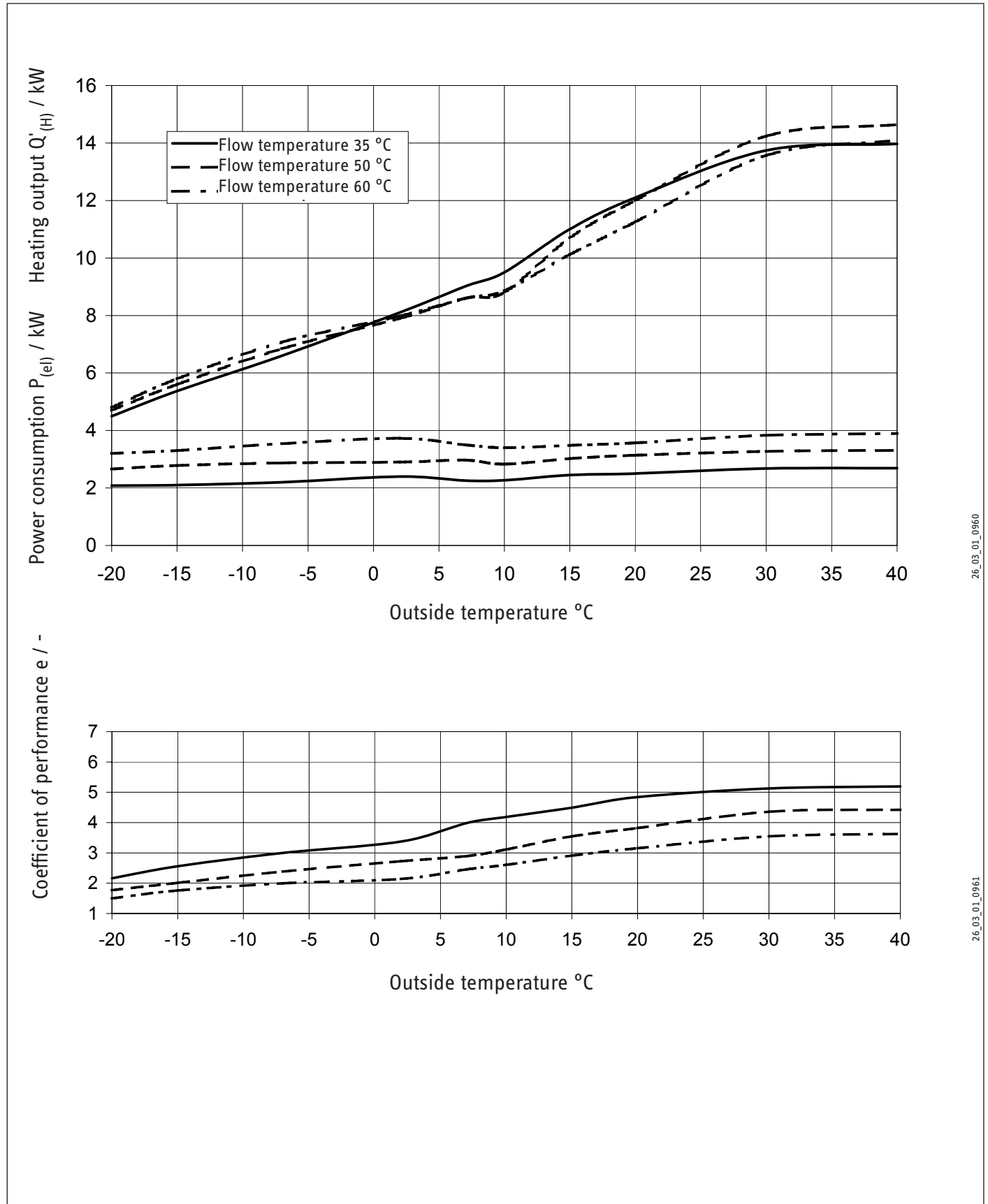

26\_03\_01\_0960

19

# INSTALLATION Specification

## Heating output diagram WPL 18 E | WPL 18 cool

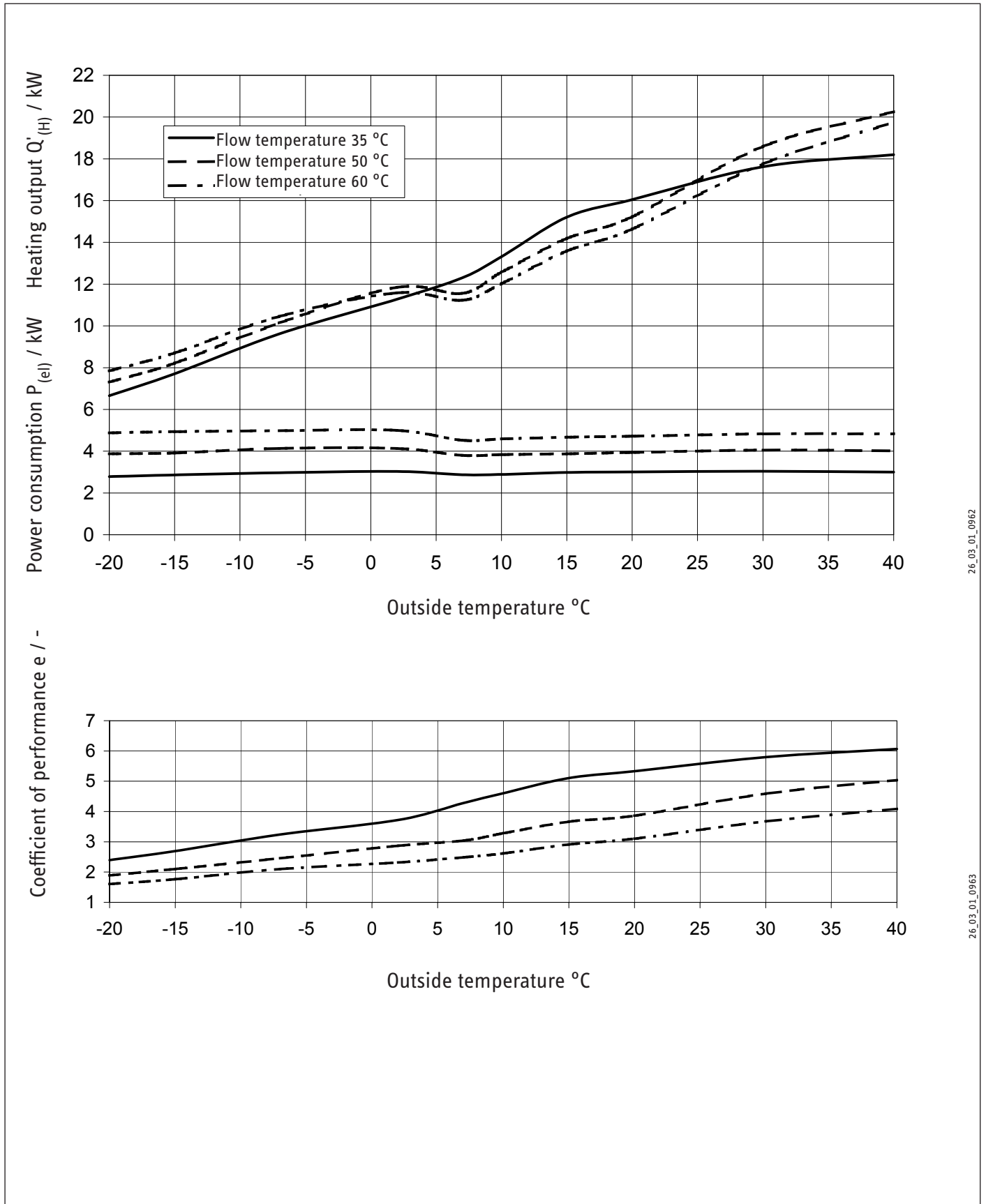

26\_03\_01\_0962

26\_03\_01\_0963

# INSTALLATION Specification

## Heating output diagram WPL 23 E



### Note

The output data for the WPL 23 cool can be found in the specification (see "Data table").

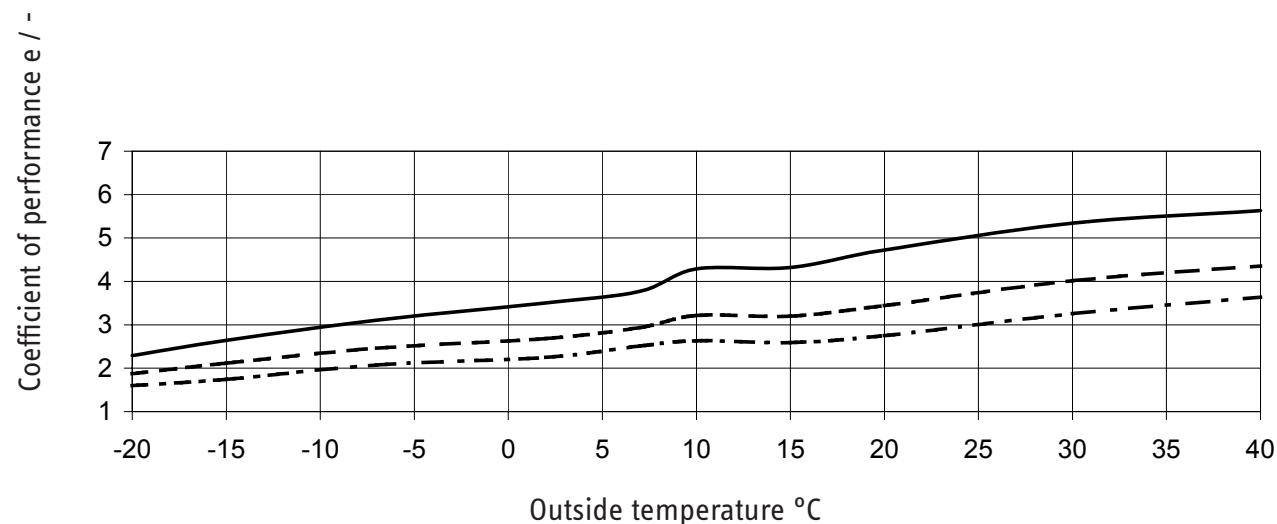
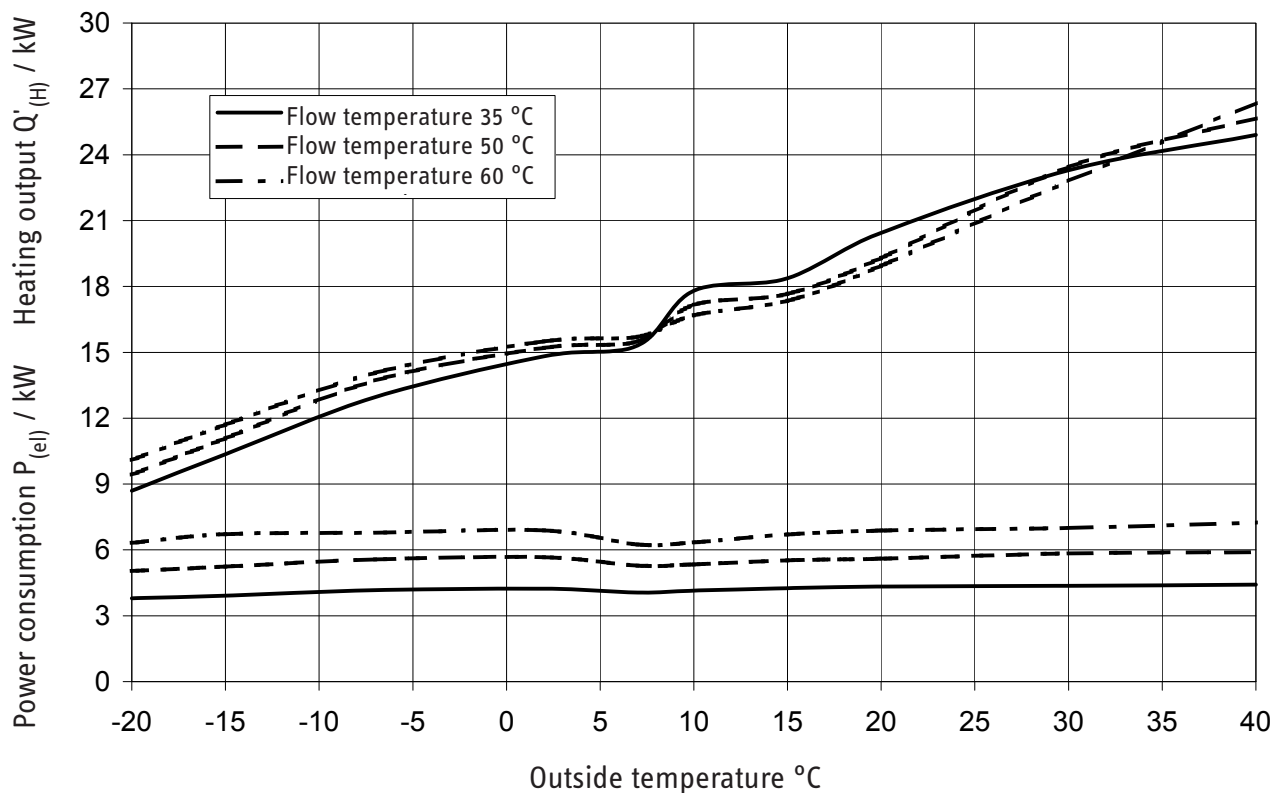

26\_03\_01\_0964

26\_03\_01\_0965

# INSTALLATION Specification

Cooling capacity diagram WPL 13 cool

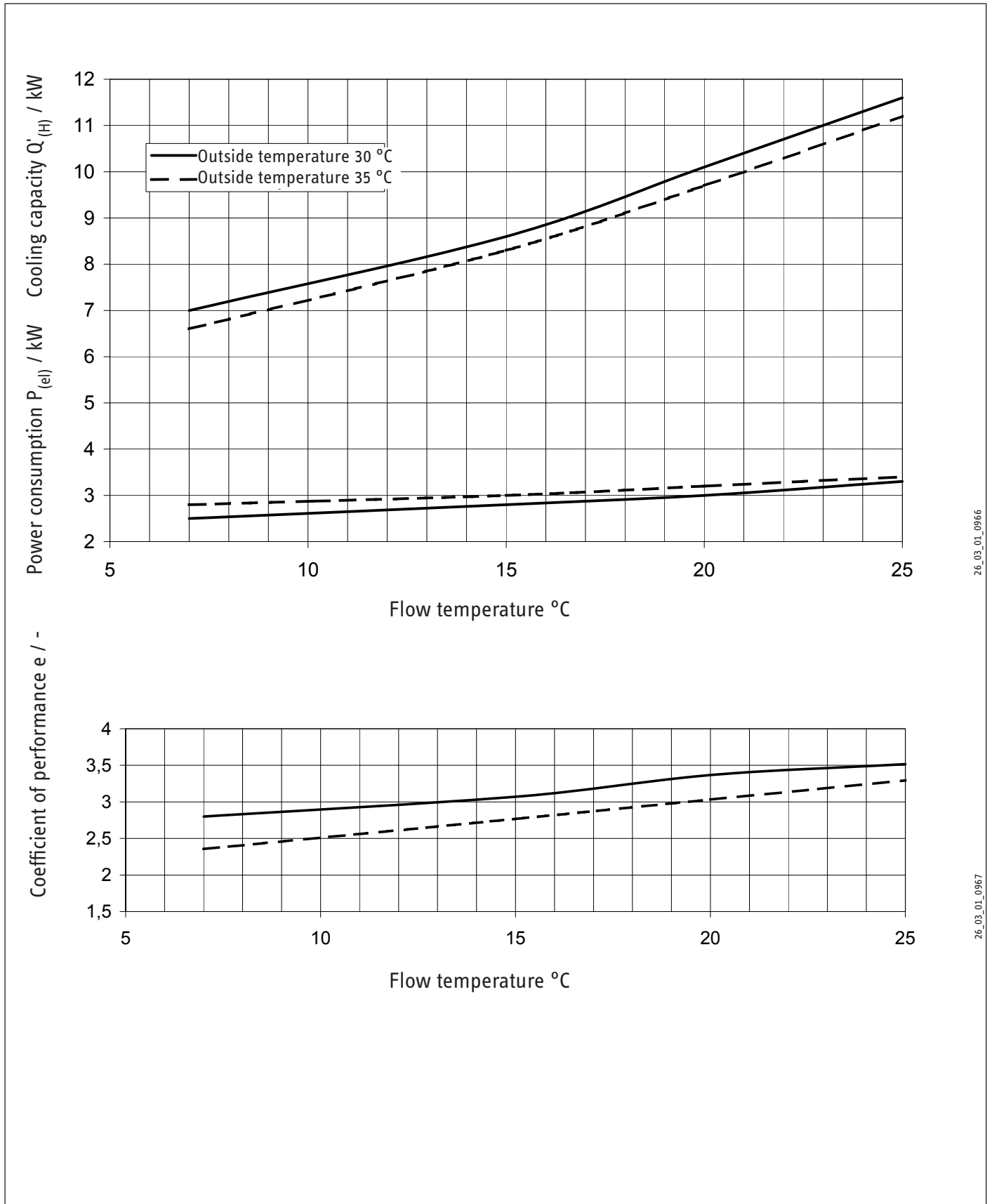

26\_03\_01\_0966

26\_03\_01\_0967

# INSTALLATION Specification

Cooling capacity diagram WPL 18 cool

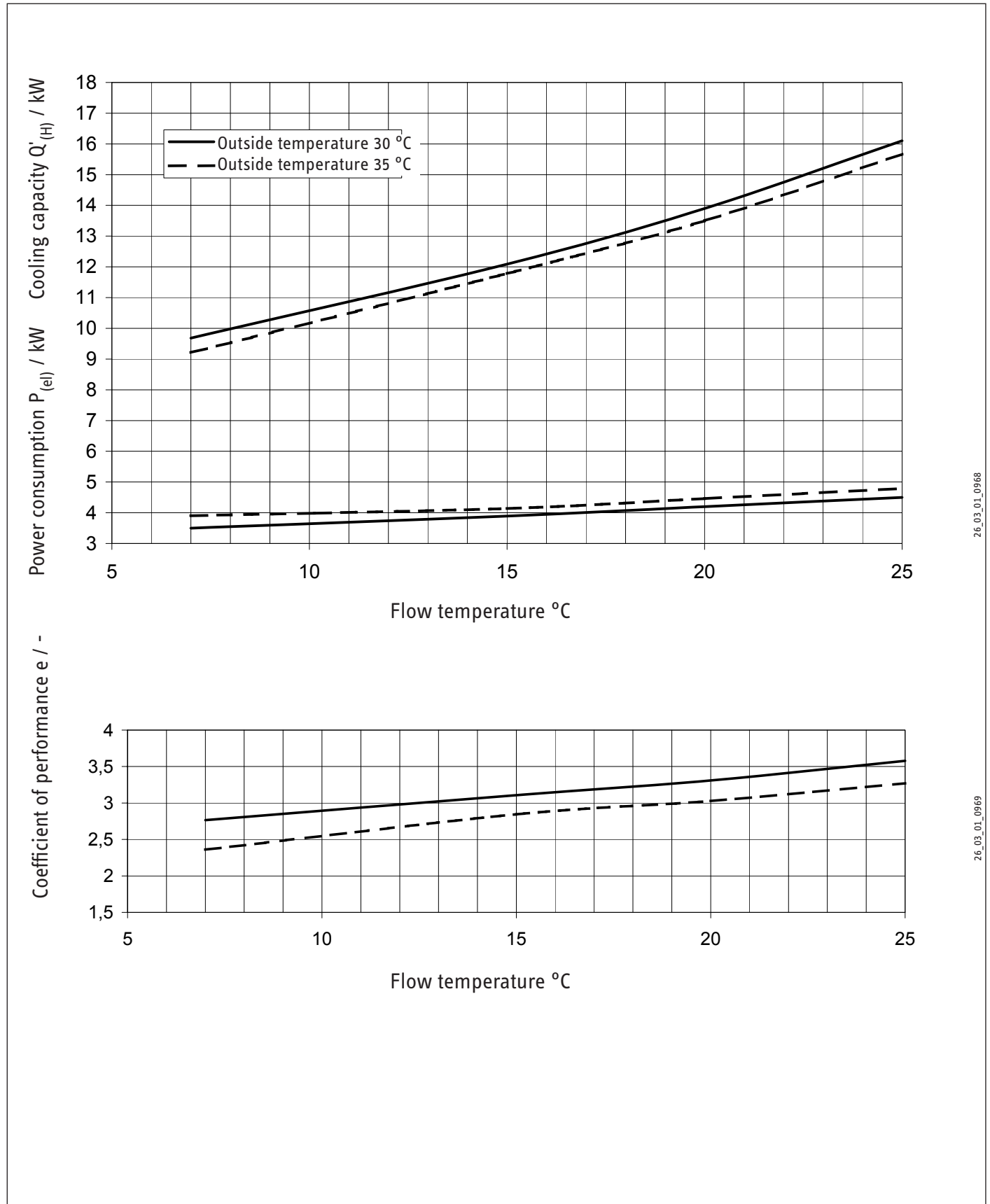

26\_03\_01\_0968

26\_03\_01\_0969

# INSTALLATION Specification

Cooling capacity diagram WPL 23 cool

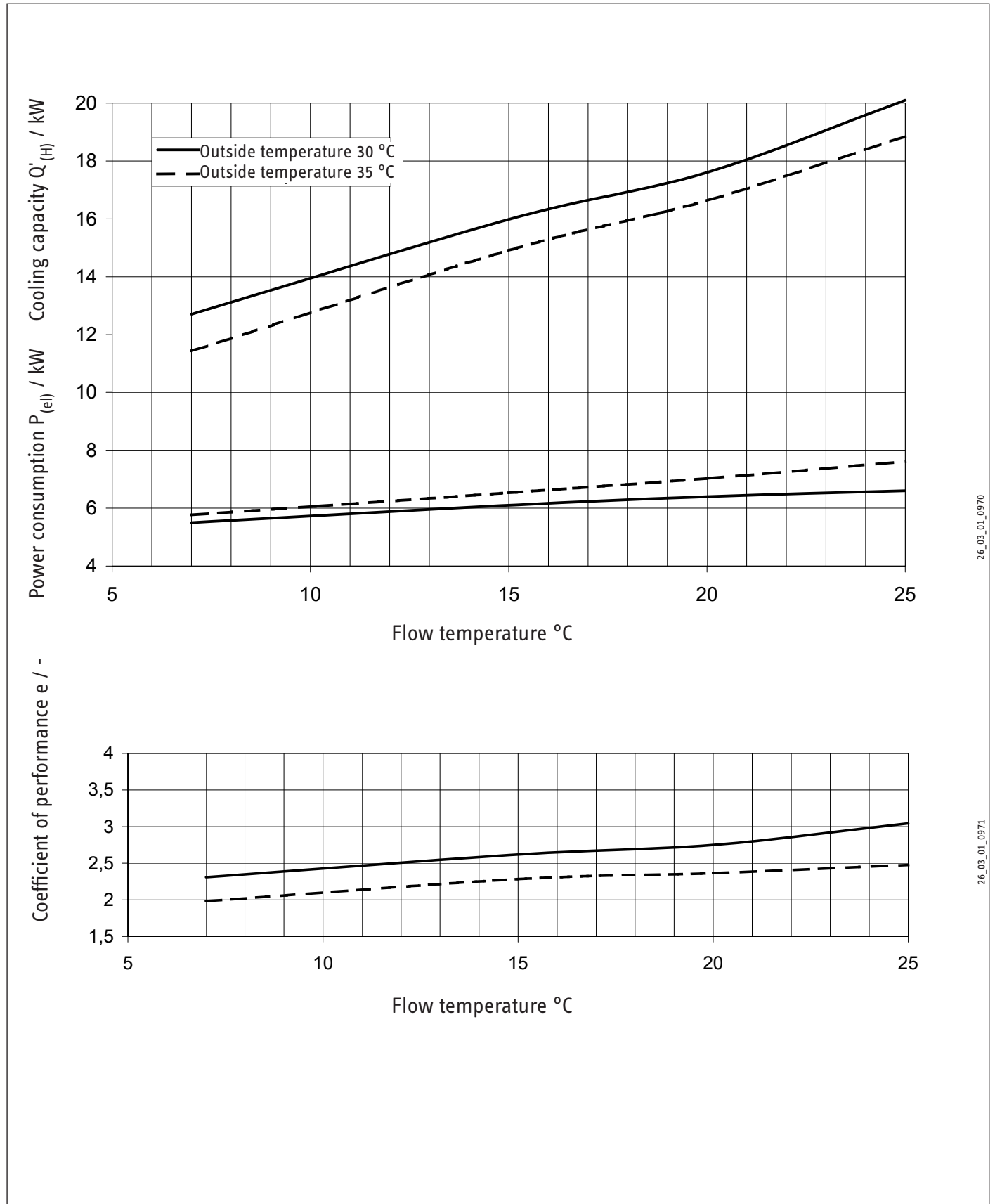

26\_03\_01\_0970

26\_03\_01\_0971

# INSTALLATION Specification

## 18.4 Data table

The output data refers to new appliances with clean heat exchangers.

The power consumption of the integral auxiliary drives represents the maximum value and may vary subject to operating point.

The power consumption of the integral auxiliary drives is included in the output data for the appliance (to EN 14511).

		WPL 13 E	WPL 13 cool	WPL 18 E	WPL 18 cool	WPL 23 E	WPL 23 cool
		227756	223400	227757	223401	227758	223402
<b>Heating output</b>							
Heating output at A10/W35 (EN 14511)	kW	9.5	9.5	13.4	13.4	18.5	
Heating output at A7/W35 (EN 14511)	kW	8.93	9.01	12.9	12.9	16.56	14.45
Heating output at A2/W35 (EN 14511)	kW	8.09	8.1	11.3	11.3	15.73	14.14
Heating output at A-7/W35 (EN 14511)	kW	6.77	6.6	9.72	9.72	13.21	12.27
Max. heating output in silent mode at A-7/W35	kW	6.27	6.27	9.23	9.23	12.55	11.65
Cooling capacity at A35/W20	kW		9.7		13.5		15.8
Cooling capacity at A35/W7	kW		6.7		9.2		12.5
<b>Power consumption</b>							
Power consumption at A10/W35 (EN 14511)	kW	2.1	2.1	2.9	2.9	4.15	
Power consumption at A7/W35 (EN 14511)	kW	2.05	2.05	2.89	2.89	4.15	4.10
Power consumption at A2/W35 (EN 14511)	kW	2.15	2.15	3.03	3.03	4.35	4.38
Power consumption at A-7/W35 (EN 14511)	kW	2.11	2.11	2.97	2.97	4.21	4.21
Power consumption, cooling at A35/W20	kW		3.3		4.5		7.2
Power consumption, cooling at A35/W7	kW		2.8		3.9		5.9
Max. power consumption, fan heating	kW	0.29	0.29	0.29	0.29	0.29	0.29
Power consumption, emergency/booster heater	kW	8.8	8.8	8.8	8.8	8.8	8.8
<b>Coefficient of performance</b>							
COP at A10/W35 (EN 14511)		4.5	4.5	4.6	4.6	4.4	
COP at A7/W35 (EN 14511)		4.35	4.35	4.46	4.46	3.99	3.52
COP at A2/W35 (EN 14511)		3.76	3.4	3.73	3.7	3.62	3.23
COP at A-7/W35 (EN 14511)		3.2	3.2	3.27	3.27	3.14	2.91
Cooling capacity factor at A35/W20			2.9		3		2.5
Cooling capacity factor at A35/W7			2.4		2.4		2.1
<b>Sound emission data</b>							
Sound power level outdoor installation (EN 12102)	dB(A)	62	62	65	65	65	65
Max. sound power level, outdoor installation, silent mode	dB(A)	60	60	63	63	63	63
Sound power level for indoor installation (EN 12102)	dB(A)	56	56	57	57	58	58
Sound power level for indoor installation, air intake/discharge (EN 12102)	dB(A)	61	61	61	61	61	61
Sound pressure level at 1 m distance in a free field	dB(A)	53	53	53	53	53	53
Sound pressure level at 5 m distance in a free field	dB(A)	39	39	39	39	39	39
Sound pressure level at 10 m distance in a free field	dB(A)	33	33	33	33	33	34
<b>Application limits</b>							
Min. application limit, heat source	°C	-20	-20	-20	-20	-20	-20
Max. application limit, heat source	°C	40	40	40	40	40	40
Application limit cooling heat source min.	°C		20		20		20
Application limit cooling heat source max.	°C		40		40		40
Min. application limit on the heating side	°C	15	15	15	15	15	15
Max. application limit on the heating side	°C	60	60	60	60	60	60
Min. application limit - cooling on the heating side	°C		7		7		
Max. application limit cooling on the heating side	°C		25		25		
Application limit cooling on the heating side 35 °C	°C						20
Application limit cooling on the heating side 40 °C	°C						12
<b>Energy data</b>							
Energy efficiency class		A+/A++	A+/A+	A+/A++	A+/A++	A+/A+	A+/A+



# INSTALLATION Specification

		WPL 13 E	WPL 13 cool	WPL 18 E	WPL 18 cool	WPL 23 E	WPL 23 cool
<b>Electrical data</b>							
Max. power consumption without emergency/booster heater	kW	4.4	4.1	5.4	5.3	7.6	7.9
Frequency	Hz	50	50	50	50	50	50
Starting current (with/without starting current limiter)	A	24/-	24/-	26/-	26/-	30/-	30/-
Compressor fuse/MCB	A	3 x C 16	3 x C 16	3 x C 16	3 x C 16	3 x C 16	3 x C 16
MCB/fuse protection, emergency/booster heater	A	3 x B 16	3 x B 16	3 x B 16	3 x B 16	3 x B 16	3 x B 16
Control unit fuse/MCB	A	1 x B 16	1 x B 16	1 x B 16	1 x B 16	1 x B 16	1 x B 16
Compressor phases		3/N/PE	3/N/PE	3/N/PE	3/N/PE	3/N/PE	3/N/PE
Emergency/booster heater phases		3/N/PE	3/N/PE	3/N/PE	3/N/PE	3/N/PE	3/N/PE
Control unit phases		1/N/PE	1/N/PE	1/N/PE	1/N/PE	1/N/PE	1/N/PE
Rated voltage, emergency/booster heater	V	400	400	400	400	400	400
Rated voltage, compressor	V	400	400	400	400	400	400
Rated voltage, control unit	V	230	230	230	230	230	230
<b>Versions</b>							
Flow/return connection		G 1 1/4 A	G 1 1/4 A	G 1 1/4 A	G 1 1/4 A	G 1 1/4 A	G 1 1/4 A
Condenser material		1.4401/Cu	1.4401/Cu	1.4401/Cu	1.4401/Cu	1.4401/Cu	1.4401/Cu
Refrigerant		R407 C	R407 C	R407 C	R407 C	R407 C	R407 C
Refrigerant charge	kg	3.2	5.9	3.4	5.2	3.4	4.9
CO <sub>2</sub> equivalent (CO <sub>2</sub> e)	t	5.68	10.47	6.03	9.22	6.03	8.69
Global warming potential of the refrigerant (GWP100)		1774	1774	1774	1774	1774	1774
Frost protection		X	X	X	X	X	X
Defrost type		Circuit reversal	Circuit reversal	Circuit reversal	Circuit reversal	Circuit reversal	Circuit reversal
IP rating		IP14B	IP14B	IP14B	IP14B	IP14B	IP14B
<b>Dimensions</b>							
Height	mm	1116	1116	1116	1116	1116	1116
Width	mm	784	784	784	784	784	784
Depth	mm	1182	1182	1182	1182	1182	1182
Height (outdoor installation)	mm	1434	1434	1434	1434	1434	1434
Width (outdoor installation)	mm	1240	1240	1240	1240	1240	1240
Depth (outdoor installation)	mm	1280	1280	1280	1280	1280	1280
Height (indoor installation)	mm	1182	1182	1182	1182	1182	1182
Width (indoor installation)	mm	800	800	800	800	800	800
Depth (indoor installation)	mm	1240	1240	1240	1240	1240	1240
<b>Weights</b>							
Weight	kg	205	210	212	214	211	220
Total weight - outdoor installation	kg	331	336	338	340	337	346
Total weight, indoor installation	kg	292	297	299	301	298	307
<b>Connections</b>							
Air hose intake and discharge connectors		DN 560	DN 560	DN 560	DN 560	DN 560	DN 560
<b>Water quality requirements</b>							
Water hardness	°dH	≤3	≤3	≤3	≤3	≤3	≤3
Chloride	mg/l	<30	<30	<30	<30	<30	<30
pH value (with aluminium compounds)		8.0-8.5	8.0-8.5	8.0-8.5	8.0-8.5	8.0-8.5	8.0-8.5
pH value (without aluminium compounds)		8.0-10.0	8.0-10.0	8.0-10.0	8.0-10.0	8.0-10.0	8.0-10.0
Conductivity (softening)	µS/cm	<1000	<1000	<1000	<1000	<1000	<1000
Conductivity (desalination)	µS/cm	20-100	20-100	20-100	20-100	20-100	20-100
Oxygen 8-12 weeks after filling (softening)	mg/l	<0.02	<0.02	<0.02	<0.02	<0.02	<0.02
Oxygen 8-12 weeks after filling (desalination)	mg/l	<0.1	<0.1	<0.1	<0.1	<0.1	<0.1
<b>Values</b>							
Heating flow rate (EN 14511) at A7/W35, B0/W35 and 5 K	m <sup>3</sup> /h	1.45	1.55	2.22	2.12	2.85	2.64
Nominal heating flow rate at A2/W35, B0/W35 and 7 K	m <sup>3</sup> /h	1	1	1.39	1.39	1.94	1.82
Min. heating flow rate	m <sup>3</sup> /h	1	1	1.2	1.2	1.4	1.4
Flow rate on heat source side	m <sup>3</sup> /h	3500	3500	3500	3500	3500	3500
Total available external pressure differential on heat source side	hPa	1.0	1.0	1.0	1.0	1.0	
Max. available external pressure differential, heat source side, intake side	hPa	0.8	0.8	0.8	0.8	0.8	
Internal pressure differential	hPa	70	70	110	110	200	200

### **Guarantee**

The guarantee conditions of our German companies do not apply to appliances acquired outside of Germany. In countries where our subsidiaries sell our products a guarantee can only be issued by those subsidiaries. Such guarantee is only granted if the subsidiary has issued its own terms of guarantee. No other guarantee will be granted.

We shall not provide any guarantee for appliances acquired in countries where we have no subsidiary to sell our products. This will not affect warranties issued by any importers.

### **Environment and recycling**

We would ask you to help protect the environment. After use, dispose of the various materials in accordance with national regulations.

---

## NOTES

---

## Deutschland

STIEBEL ELTRON GmbH & Co. KG  
Dr.-Stiebel-Straße 33 | 37603 Holzminden  
Tel. 05531 702-0 | Fax 05531 702-480  
info@stiebel-eltron.de  
www.stiebel-eltron.de

## Verkauf

Tel. 05531 702-110 | Fax 05531 702-95108 | info-center@stiebel-eltron.de

## Kundendienst

Tel. 05531 702-111 | Fax 05531 702-95890 | kundendienst@stiebel-eltron.de

## Ersatzteilverkauf

Tel. 05531 702-120 | Fax 05531 702-95335 | ersatzteile@stiebel-eltron.de

## Australia

STIEBEL ELTRON Australia Pty. Ltd.  
6 Prohasky Street | Port Melbourne VIC 3207  
Tel. 03 9645-1833 | Fax 03 9645-4366  
info@stiebel.com.au  
www.stiebel.com.au

## Austria

STIEBEL ELTRON Ges.m.b.H.  
Gewerbegebiet Neubau-Nord  
Margaritenstraße 4 A | 4063 Hörsching  
Tel. 07221 74600-0 | Fax 07221 74600-42  
info@stiebel-eltron.at  
www.stiebel-eltron.at

## Belgium

STIEBEL ELTRON bvba/sprl  
't Hofveld 6 - D1 | 1702 Groot-Bijgaarden  
Tel. 02 42322-22 | Fax 02 42322-12  
info@stiebel-eltron.be  
www.stiebel-eltron.be

## China

STIEBEL ELTRON (Guangzhou) Electric  
Appliance Co., Ltd.  
Rm 102, F1, Yingbin-Yihao Mansion, No. 1  
Yingbin Road  
Panyu District | 511431 Guangzhou  
Tel. 020 39162209 | Fax 020 39162203  
info@stiebeleltron.cn  
www.stiebeleltron.cn

## Czech Republic

STIEBEL ELTRON spol. s r.o.  
K Hájům 946 | 155 00 Praha 5 - Stodůlky  
Tel. 251116-111 | Fax 235512-122  
info@stiebel-eltron.cz  
www.stiebel-eltron.cz

## Finland

STIEBEL ELTRON OY  
Kapinakuja 1 | 04600 Mäntsälä  
Tel. 020 720-9988  
info@stiebel-eltron.fi  
www.stiebel-eltron.fi

## France

STIEBEL ELTRON SAS  
7-9, rue des Selliers  
B.P 85107 | 57073 Metz-Cédex 3  
Tel. 0387 7438-88 | Fax 0387 7468-26  
info@stiebel-eltron.fr  
www.stiebel-eltron.fr

## Hungary

STIEBEL ELTRON Kft.  
Gyár u. 2 | 2040 Budaörs  
Tel. 01 250-6055 | Fax 01 368-8097  
info@stiebel-eltron.hu  
www.stiebel-eltron.hu

## Japan

NIHON STIEBEL Co. Ltd.  
Kowa Kawasaki Nishiguchi Building 8F  
66-2 Horikawa-Cho  
Saiwai-Ku | 212-0013 Kawasaki  
Tel. 044 540-3200 | Fax 044 540-3210  
info@nihonstiebel.co.jp  
www.nihonstiebel.co.jp

## Netherlands

STIEBEL ELTRON Nederland B.V.  
Daviottenweg 36 | 5222 BH 's-Hertogenbosch  
Tel. 073 623-0000 | Fax 073 623-1141  
info@stiebel-eltron.nl  
www.stiebel-eltron.nl

## Poland

STIEBEL ELTRON Polska Sp. z O.O.  
ul. Działkowa 2 | 02-234 Warszawa  
Tel. 022 60920-30 | Fax 022 60920-29  
biuro@stiebel-eltron.pl  
www.stiebel-eltron.pl

## Russia

STIEBEL ELTRON LLC RUSSIA  
Urzhumskaya street 4,  
building 2 | 129343 Moscow  
Tel. 0495 7753889 | Fax 0495 7753887  
info@stiebel-eltron.ru  
www.stiebel-eltron.ru

## Slovakia

TATRAMAT - ohrievače vody s.r.o.  
Hlavná 1 | 058 01 Poprad  
Tel. 052 7127-125 | Fax 052 7127-148  
info@stiebel-eltron.sk  
www.stiebel-eltron.sk

## Switzerland

STIEBEL ELTRON AG  
Industrie West  
Gass 8 | 5242 Lupfig  
Tel. 056 4640-500 | Fax 056 4640-501  
info@stiebel-eltron.ch  
www.stiebel-eltron.ch

## Thailand

STIEBEL ELTRON Asia Ltd.  
469 Moo 2 Tambol Klong-Jik  
Amphur Bangpa-In | 13160 Ayutthaya  
Tel. 035 220088 | Fax 035 221188  
info@stiebeleltronasia.com  
www.stiebeleltronasia.com

## United Kingdom and Ireland

STIEBEL ELTRON UK Ltd.  
Unit 12 Stadium Court  
Stadium Road | CH62 3RP Bromborough  
Tel. 0151 346-2300 | Fax 0151 334-2913  
info@stiebel-eltron.co.uk  
www.stiebel-eltron.co.uk

## United States of America

STIEBEL ELTRON, Inc.  
17 West Street | 01088 West Hatfield MA  
Tel. 0413 247-3380 | Fax 0413 247-3369  
info@stiebel-eltron-usa.com  
www.stiebel-eltron-usa.com

**STIEBEL ELTRON**



Irrtum und technische Änderungen vorbehalten! | Subject to errors and technical changes! | Sous réserve d'erreurs et de modifications techniques! | Onder voorbehoud van vergissingen en technische wijzigingen! | Salvo error o modificación técnica! | Excepto erro ou alteração técnica | Zastrzeżone zmiany techniczne i ewentualne błędy | Omyly a technické změny jsou vyhrazeny! | A muszaki változtatások és tévedések jogát fenntartjuk! | Отсутствие ошибок не гарантируется. Возможны технические изменения. | Chyby a technické zmeny sú vyhradené!

Stand 9147